

**QUARTERING AND BREAKING  
SHEAR  
USER MANUAL  
CM-900**

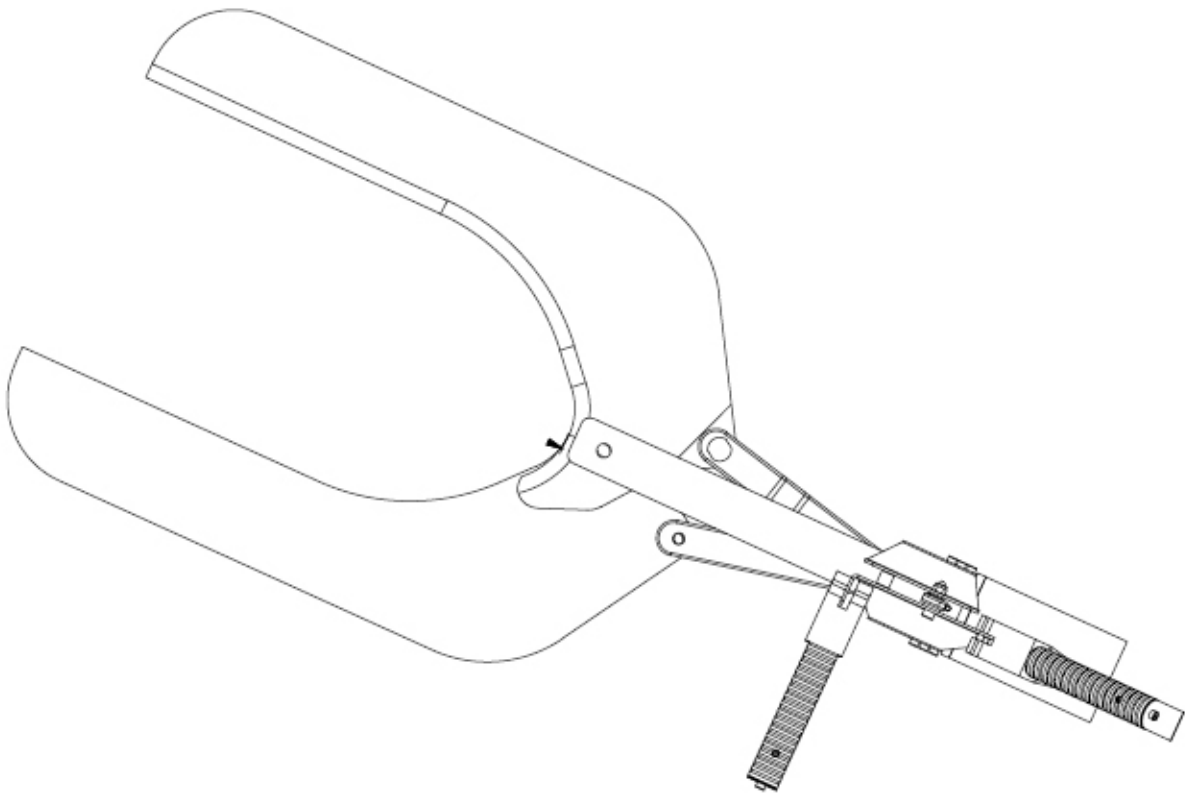

## COMPANY INFORMATION

Registered Trademark: **LALE**

Manufacturer Firm: **CEMSAN A.Ş.**

E-Mail: **info@lalesaws.com**

Web Address: **www.lalesaws.com**

### FACTORY

Address: **Saray Mahallesi, 4. Cad. No: 49**  
**Kahramankazan/Ankara/Türkiye**

Phone Number: **+90 312 801 02 22**



## TABLE OF CONTENTS

About The Manual .....	4-10
Transferring and Storing .....	11
Assembly and Engaging .....	12
Assembly of The Balancer .....	13
Balancer Usage .....	14-17
CM-900 Quartering and Breaking Shear .....	18
Electrical Connection .....	19
Hydraulic Connection .....	20
Spare Parts List - General Overview .....	21
CM-900 Engine Label .....	22
CM-900 Technical Specifications .....	22
CM-900 Safety Precautions .....	23
CM-900 Troubleshooting .....	24
CM-900 Maintenance Instruction .....	25
CM-900 Application/Description .....	26-31
CM-900 Installation/Operating Principle .....	32-33

## ABOUT THE MANUAL

■ This manual has been prepared for you to work quickly and safely.

**The manual is a component of the machine, and it includes the following:**

- Important information
- Usage of the machine in a safe and effective way
- Cleaning and disinfecting for maintenance

Examine the manual carefully before operating the machine.

Be sure that you obey the safety instructions completely.

Always keep the manual near to the machine.

The manufacturer will not take any responsibility for the user errors

### To Whom Do We Appeal?

This manual is a necessity for the owners of slaughterhouse, experts, butchers, apprentices, and technical personnels. It has been prepared for the people who have basic know-how.

### Conservation of The Manual

This manual is a part of the machine, and must be accessible everywhere!

Operating and maintaining personnel shall be instructed that they must keep the manual with the machine all the time during the service life of the machine.

### Order Items

Various parts of this manual enables you to define the specific order items and meaning of the text.

The manual includes reading parts, symbol explainings, numerations, instruction steps, step by step series with a particular order, references to another parts, technical schemes, important supplementary infos, or details regarding to usage of the machine.

### About The Manufacturer Firm

CEMSAN Slaughterhouse Systems has been supplying the most modern slaughtering and integrated meat processing facilities such as slaughtering equipment, meat processing equipment, storage, cooling rooms and meat handling systems for slaughterhouses that slaughter cattle and sheep for 39 years. As a result of our R&D activities carried out for many years, we are pleased to present LALE Cutting Tools to all of our customers in accordance with EUROPEAN QUALITY STANDARDS.

As a leading brand in slaughtering technologies with over 550 slaughterhouse and meat processing plant references, it attaches utmost importance to hygiene, ergonomics, safety, quality, animal welfare and



## ABOUT THE MANUAL

butcher health in every production. It always prioritizes customer satisfaction, and takes immediate action against all problems that may occur with our quality technical service. We are able to meet all kinds of cutting requirements of all slaughterhouses and meat processing plants of all capacities with the highest standards, including production, assembly and after-sales services with our wide range of products.

### Responsibilities and Warranty Terms

All the information and instructions relating to the operation and maintenance of the machine in this manual are presented by considering our experience and knowledge. LALE Cutting Tools refuses any responsibility for the demands which are not covered by guarantee, except for the demands legally indicated and agreed on by both buyer and seller.

### Significant Points for Your Safety

It is explained in this part safety precautions and tools for safety. Be sure that you read and understand the following safety instructions before operating the machine. This part aims to lead you about safety issues regarding to the usage of machine.

The original version of the manual has been written in Turkish. In case of any inconsistency or contradiction between Turkish and English version, The Turkish version shall be valid.

**Warranty shall be null and void in following situations:**

- When there is disobedience to the information in this manual.
- When the machine is used in contrary to its purpose.
- Usage of spare parts or part unapproved by LALE Brand
- Changing parts of other materials without getting approval of LALE brand's managers in advance.
- When the machine is not operated in a proper way or by untrained personnel.
- Any damage occurrence while cutting.
- When the safety device or equipments are removed, taken off, or substituted with another unapproved material.
- When the machine is not cleaned properly or professionally.
- When the machine is exposed to chemical or mechanical stress.
- When the maintenance is made in a wrong way or maintenance periods or instructions is neglected.
- Spare parts

In specific situations, the written approval shall be gotten by discussing with LALE brand managers in case some modifications or settings are desired.

## ABOUT THE MANUAL

### Warnings to Be Taken Seriously for Safety



Warnings against sharp-edged machine parts. Danger of cutting, injuring, or chopping the limbs.



Warning against rotating blade saw and saws in common.



Warning against dangerous electric potential.



Warning against common hazards.



Warning against hot surface.



Danger for crushing your hand or fingers

### Mandatory Occupational Health and Safety Signs to Be Used



Put on enduring and covered-closed shoes.



Wear protective gloves.



Wear eye-protecting equipments.



Wear hearing conservation.



Wear hair net or casque.



Wear protective uniform



## ABOUT THE MANUAL

### Forbidden Actions



Do Not use high pressured purifier for cleaning

### Safety Signs on Machine



Warning for the saw's direction.



Warning against cutting.



Warning against dangerous electric potential

### About The Conservation of The Manual

Manual must be always accessible by operating and maintaining personnel during the whole service life of the machine. For this reason, keep the manual near to the machine all the time!

### Responsibilities of Business Manager

Keep in mind that in an establishment dealing with the meat market, it is obligatory to give permission only to the older than 18 year-old and to the people who have insurance and are familiar with their work, in accordance with the regulations and rules relating to health and safety. Even when they have completed their occupational training and read safety instructions, their safety must be examined by an official.

Facility manager is responsible for providing training of each employee working in operation of the machine in most effective way. Trained personnel shall work on machine under only the following circumstances:

- The machine must be completely functional.
- Safety points must be checked regularly.
- Business managing director must provide the density of the lighting to be at least 500 lux
- Work places must be at least 1,5m wide, ensure at least 1 m depth per a personnel to enable the personnel to move together with the machine.

## ABOUT THE MANUAL

- It must be inspected that the personnel using the machine has a work uniform and protective equipments coherent to the OHS regulations.
- Surface material of the work platform must not be wet, and not carry the risk of slipping on oily surface.
- The place where the machine is must be suitable for hygiene and work place rules.
- Be sure that on the area/platform, the escapeways and/or their functions are not blocked at the moment of accident.

### Responsibilities of Employees

- Operating personnels must be informed and trained by the employer properly.
- The personnel must be the one who read and comprehended the safety instructions and are trained, know operating the machine.
- The personnel must be familiar to the manual.
- They must have completed the legal trainings relating to the accident prevention regulations and current OHS.
- Along with assembly, maintenance, and repair, problem solving must be done only by qualified personnel. They must have knowledge about warranty conditions.
- The personnel must keep the work place tidy and clean. Untidy work places and areas may cause accidents.
- The personnel must wear personal protective equipment provided for them.
- The child, young, and untrained must be kept away from the machine.

### Electric Safety

#### About The Purpose of The Machine's Usage

Hydraulic Quartering and Breaking Shear for high capacity slaughterhouses.

The points which have huge significance:

- It can be run by only one operator.
- It can run only when specific safety devices are mounted.

## ABOUT THE MANUAL

### Reminders for running usage of the machine:

- Obedience to safety instructions.
- Conducting the maintenance and repair works properly.
- Cleaning the machine regularly.
- Using the original spare parts.
- That the personnel have training of how to use the machine.

### Warning Against Misusage

- Use the machine properly only for its intended purpose. In an uncertainty, consult to manufacturer.
- In no way, do not use the machine for cutting the materials such as wood, rock, plastic.
- Do not extend the cables and connection lines in the machine.
- Do not use the machine if the safety devices do not run.
- Do not use a machine with higher than 380 V in cutting area.

Any other usage apart from the ones indicated in "About the intended purpose of the machine" is accepted as contrary to the intended purpose. LALE Brand or the main manufacturer firm CEMSAN A.Ş. will not take any responsibility for damage or injure. The risk causing from inappropriate utilization belongs only to the user.

### About The Permanent Risks

Quartering and Breaking Shear CM-900 has been designed in accordance with the highest technology, and general safety and healthy rules valid in Republic of Türkiye and the European Union.

However, it is still subject to hazards which can not be eliminated with the design precaution:

- Danger of wounding in fingers and hands.
- Danger of injuring yourself due to the meat cut and bone pieces.
- Danger of injuring eyes.

## ABOUT THE MANUAL

- Breaking or flouncing of saw's blade.
- Danger of electricity arising from usage of inappropriate connection cables.

Despite all the precautionary measures, remind that undistinct residual risks may be permanent. You can minimize these risks by paying attention to the safety instructions in each part's beginning and to taking the instructions in the manual as a whole.



### ATTENTION!

#### There are sharp-edged machine parts.

Danger of cutting.

- Never put your hands near to the movable machine parts.
- Keep you hands away from the saw's blade or blade.
- Wear protective gloves for your own safety.



#### About The Electrical Danger

During all the maintenance and repair works, take the machine out of electrical power supply.



#### About The Heat Dangers

Your skin may burn when you touch it during utilization of the product due to engine's heating.

In case of a necessity to touch, hold t he machine only from it's handle, and wait for it to be cold. Never touch it before it is cold.



#### About The Mechanical Dangers

Your fingers and hand may be stuck or crushed during the process.



You will have beat risk due to the movements of the machine (twisting and kicking) while it is working.

Be careful while the machine is running. Try to stand stabile!

## TRANSFERRING AND STORING

Our machines are designed for the shipment via motorised truck, train, plane or vessel. Shipment may be separately or in multiple packages. Our machines have gone through testing process at our factory and been inspected thoroughly before they are sent out. This inspection means that the machine meets the datas given and it works accurately. The machine may get damaged despite of all the caution.

### Taking The Machine Out Of It's Package

The machine is ready as compliant with the installation, and installation rules while you open the package of the product. Installation can be done as convenient with the necessary installation articles.

As per our quality policies, the original package of the machine is made of recyclable material. Product package can be given to the places where the recyclable materials are collected. Thank you for being sensitive to environment.

- Remove all the packing materials and throw them away properly.
- Remove all the protection materials placed in the package.
- Check whether there is a shipment damage in the machine.
- Monitor the machine for inspection at the first working-hours.
- Look out whether there is a fault at the first operating. In case of any, contact immediately with our firm. Do not ever interfere in the machine.

### Conversation of The Machine

Be sure that you pay attention to the following notes for conserving the machine safely:

- Store the machine only in dry or places where will not have frost.
- Be sure that the machine is completely dry while storing the machine for a longer period of time.
- Conserve the machine in a way that it does not damage itself.
- Protect the machine against corrosion.

## ASSEMBLY AND ENGAGING

The installation and connection of the machine shall be made by the operator. LALE Brand is not responsible for the damages occurring while the assembly is being made not by the authorised operator.



### ATTENTION!

#### Active machine parts. Life-threatening.

- Before operating the machine, cut off it's electricity first and ensure it for not to be opened again by accident.
- Give permission only to the qualified electrician to work on dynamic and electrical components.



### WARNING!

It may cause life danger and severe injury if unqualified and incapable personnel are employed.

- While commissioning, it requires to allow only the trained and authorised service personnel to operate the machine.
- Only certified electricians must perform workings on the dynamic and electrical components.



### WARNING!

#### Sharp-edged machine parts. Danger of cutting yourself.

- Do not ever put your hands near or close to the moving machine parts.
- Keep your hands away from the saw's blade or the blade.
- Wear protective gloves for your own safety.

## Personel Protective Equipment

Wear personal protective equipments during assembly and operating absolutely in order to prevent any injuring.



Protective gloves



Enduring and covered-closed shoes

## ASSEMBLY OF THE BALANCER

Purpose of the balancer is to eliminate the constant weight of a tool during a vertical movement. It has been designed to be used by only one operator at one time manually.

It has been designed to be used in inner places with a temperature between of 5°C and 60°C. It is suggested that the load should be hung at the center of gravity in order for the product to be used.

In the models with locking tool, The device must be activated for stopping the bant (visible red indicator or closed padlock). Then, you must slowly manipulate the load till it is placed in lock hole (placed in about every 100 mm along the rope stroke). The balancers are in accordance with each regulations relating to workplaces.



### WARNING!

The balancers need to be inspected and maintained at regular intervals in order to run perfectly in compliance with each regulations relating to workplaces.

## BALANCER USAGE

### Tool Balancer Installation

Evaluate the working area and, if necessary, suspend the balancer from a support so that it can be used properly within an area large enough to perform the required operations. If screw fastening devices are used to install the balancer, self-locking nuts, split pins, or other safety systems must be used.

Always connect safety suspension S only to a suitably sized support, using only the standard fastening elements supplied.

The safety support must NOT be the same as the one used for the main suspension 23. If the main suspension breaks, the maximum falling distance must not exceed 100 mm. Tighten clamp nuts 20331 to a torque of 4 Nm. To prevent abnormal wear, the load must be applied vertically and, in all cases, the cable must be aligned with the direction of the load.

### Balancer Operation

Hold the tool hanging from the balancer and perform the required operations. Then move and release the tool until it balances on the balancer's vertical line. The load to be balanced must be hung from spring hook 39 (Fig. 3). After the load has been attached, the snap hook must be properly closed.

The cable must never be completely unwound; the working travel must end at least 100 mm before reaching the end limit (balancers 9502÷9509 and 9520÷9525 are equipped with an automatic limit stop system). If necessary, move and lock clamp M to stop the upward movement.

⚠ Do not lift the load if clamp M is not resting against the rope bend.

When using the balancer, always wear personal protective equipment and strictly comply with the applicable accident prevention regulations.

The following are strictly prohibited:

- Releasing the load if it is not in a vertical position
- Swinging/throwing the suspended load to another operator
- Moving the load by pulling the balancer cable
- Suspending loads outside the upper and lower limits of the permitted load capacity
- Hanging more than one tool on the balancer

⚠ The only risk associated with the use of the balancer is any uncontrolled rewinding of the balancer cable. This is a very dangerous event and can be prevented by following the instructions below:

⚠ If the spring is to be fully discharged, stop the discharge operation as quickly as possible. The spring is active and becomes fully discharged; going beyond this position will damage the spring and it must be replaced.

## BALANCER USAGE

- If, for any reason, the balancer does not rewind the cable, DO NOT attempt any intervention. Do not act on your own initiative; contact customer service immediately.
- If the cable is not fully wound onto the drum, never release the load. If the balancer cable has unwound and no load is applied to it, DO NOT attempt any intervention on your own; contact customer service immediately.

### Balancer Adjustment

To enable the balancer to balance heavier loads, use the special key to turn screw 41 in the direction indicated by the “+” symbol. For lighter loads, turn screw 41 in the direction indicated by the “-” symbol.

After adjusting the load, check that the cable moves freely over its entire length; its movement must not be restricted when the spring is fully wound. Check the operation frequently at different speeds.

**NOTE:** If the balancer’s capacity to support a suspended load decreases, this may indicate that the drum spring is about to break. Do not readjust the balancer. In all cases, support the load and immediately contact qualified maintenance personnel responsible for the equipment.

### Drum Spring Breakage

The balancer is equipped with a safety device that activates when the drum spring breaks and stops movement in order to prevent the suspended load from falling.

If the suspended tool cannot be lifted or lowered with normal force, DO NOT FORCE IT and contact customer service.

**NOTE:** Even if the drum spring is completely discharged, the balancer will stop. In this case, provided that the head of charging screw 41 protrudes approximately 4 mm from the cover, try to recharge the spring as described in the “Balancer Adjustment” section in order to restore operating conditions. If the balancer is not released, DO NOT attempt any intervention and contact customer service.

#### Manual Lock:

The balancer is equipped with a manual locking system. To stop drum rotation, turn button (6) to position (A). To restore normal operating conditions, turn button (6) to position (B).

**NOTE:** For safety reasons, the shape of the cover that stops the drum does not allow closing unless the corresponding holes on the drum are perfectly aligned.

To release it, move the load slightly upward and downward until the correct position on the drum is found.

#### OPTION “B”: Bottom Control

To lock the drum, lower the edge of the handle marked with the RED band; to release it, lower the side of the handle marked with the GREEN band.

**WARNING:** Do not leave the balancer with the drum locked and without a suspended load.

**WARNING:** If the balancer cable is not fully wound and no load is applied, do nothing other than contacting customer service immediately.

**WARNING:** Always comply with safety regulations when using electrical equipment.

## BALANCER USAGE

### Inspections and Maintenance

Maintenance may only be carried out by qualified and authorized personnel. Inspect the balancer visually on a regular basis (for example, once per shift). In particular, check the condition of suspensions (23) and S (Fig. 1), fastening screws, self-locking systems (if any), as well as the condition of hooks and the cable. If the cable shows any of the defects illustrated in Fig. 5, replace it immediately.

Do not make any modifications to the cable assembly and, in particular, do not shorten the cable. If required, please contact CEMSAN A.Ş.

- Check that the cable moves smoothly and does not produce unusual noises.
- Do not lubricate the balancer with flammable or volatile liquids.
- Do not remove any labels. Replace damaged labels.
- The balancer must be inspected at least once a year by qualified and authorized personnel.

**Never disassemble the balancer. Maintenance must only be performed by qualified and authorized personnel.**

Static and dynamic tests (Machinery Directive 2006/42/EC, Annex I, Section 4.1.3) are carried out by the manufacturer. At the end of its service life, the balancer must be disposed of in accordance with the applicable regulations.

### Warranty

The use of non-original LALE Cutting Tools spare parts will adversely affect safety and performance and, in all cases, will render the warranty void.

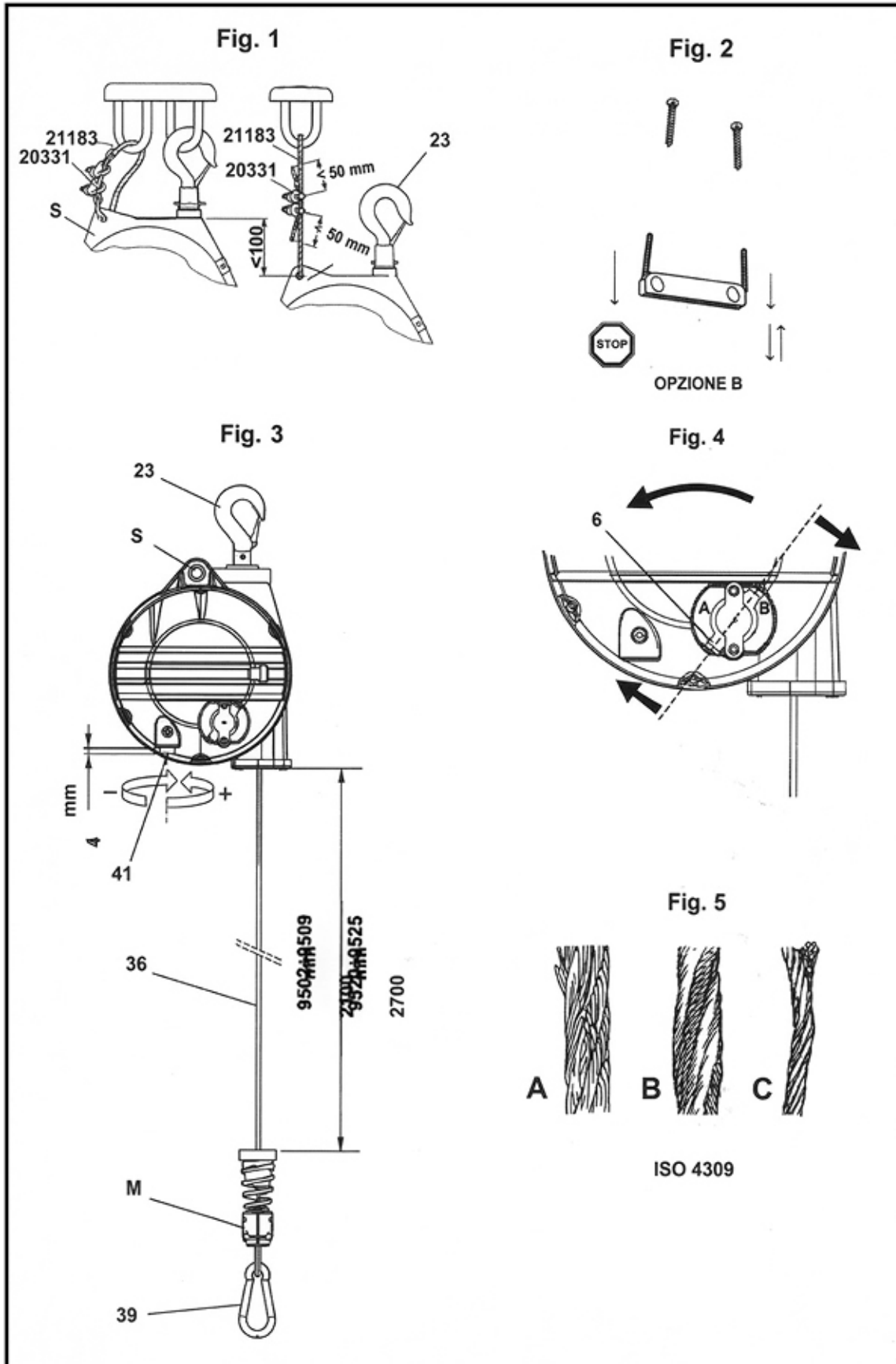

## QUARTERING AND BREAKING SHEAR

### CM-900

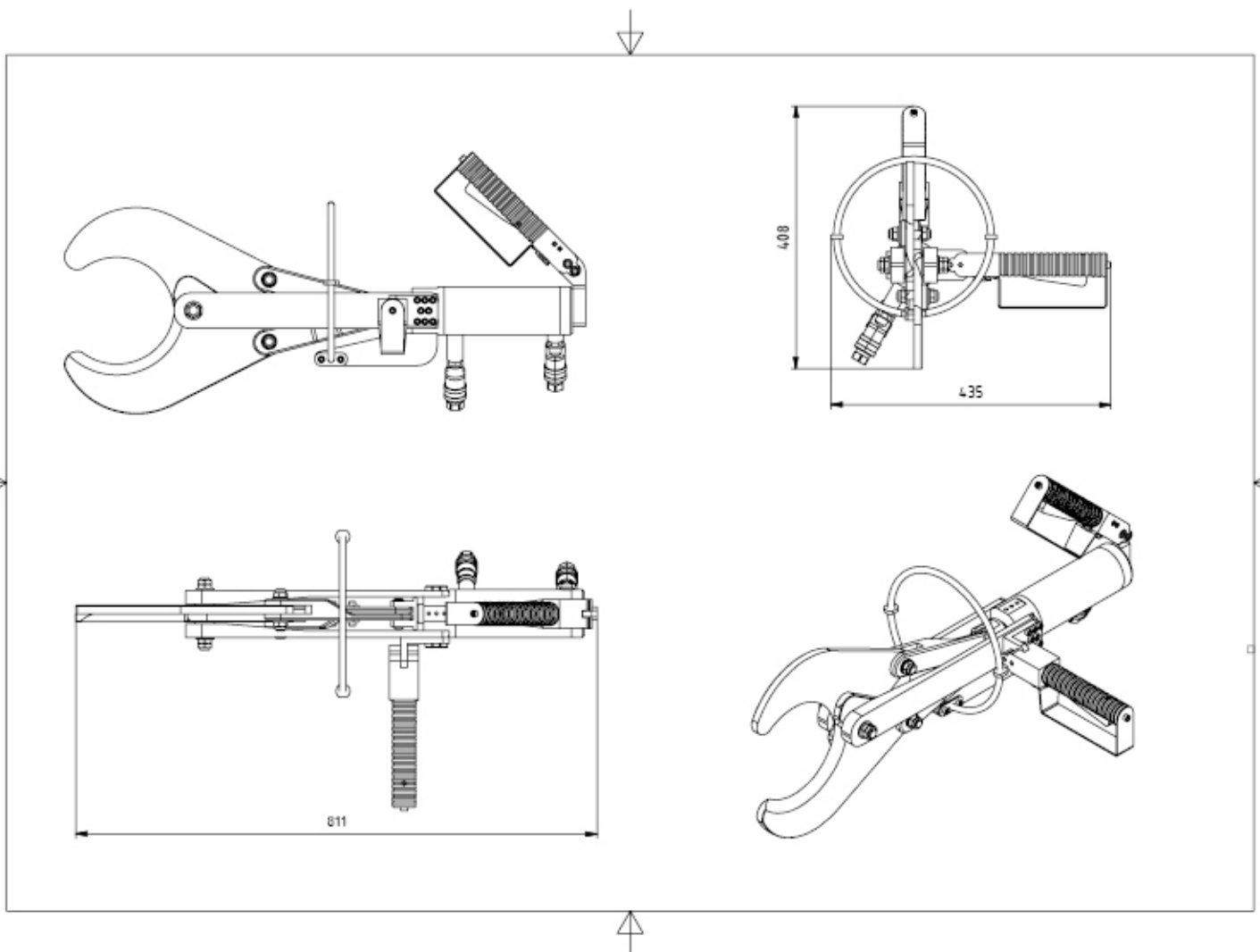

# ELECTRICAL CONNECTION

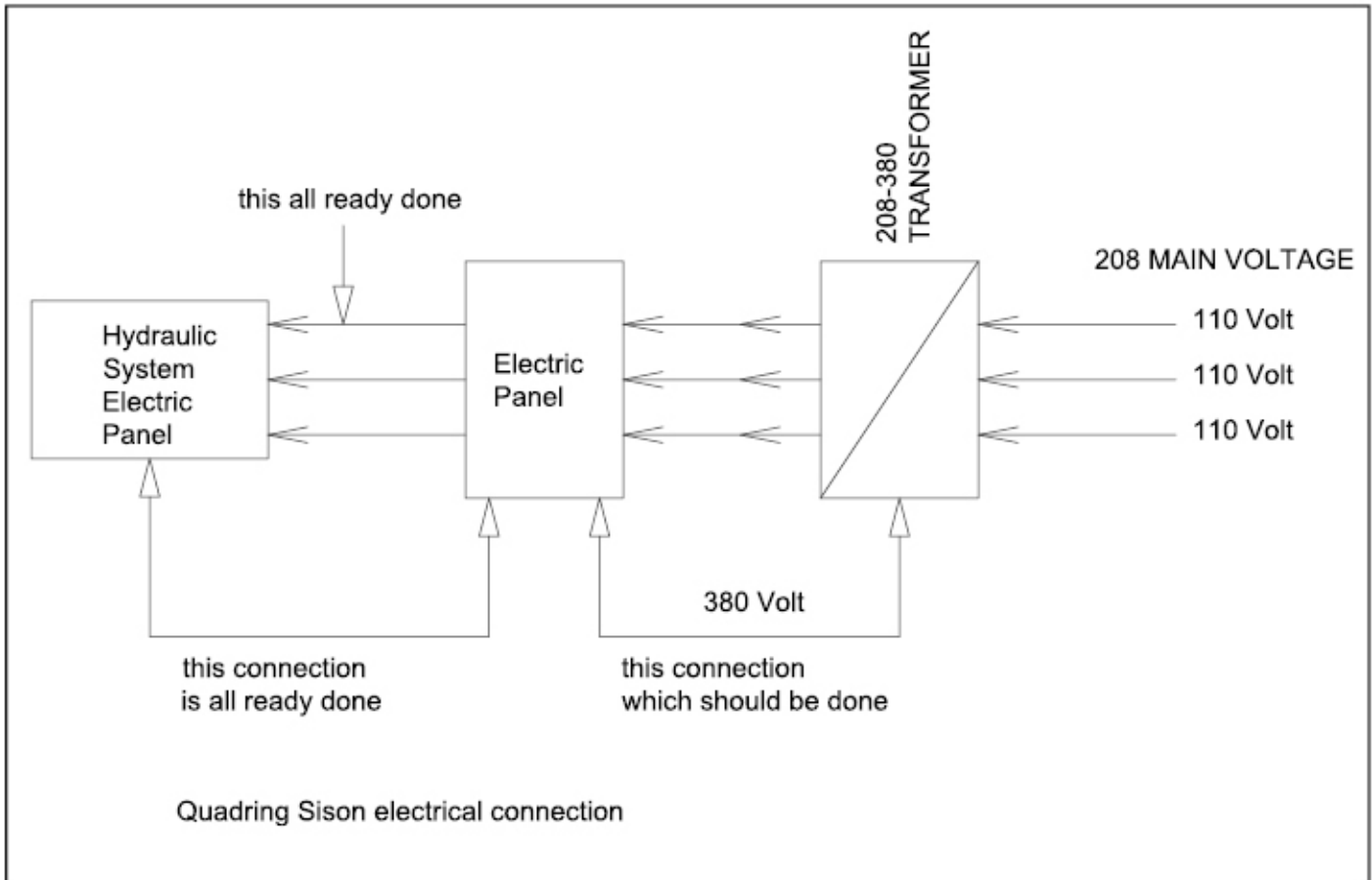

# HYDRAULIC CONNECTION

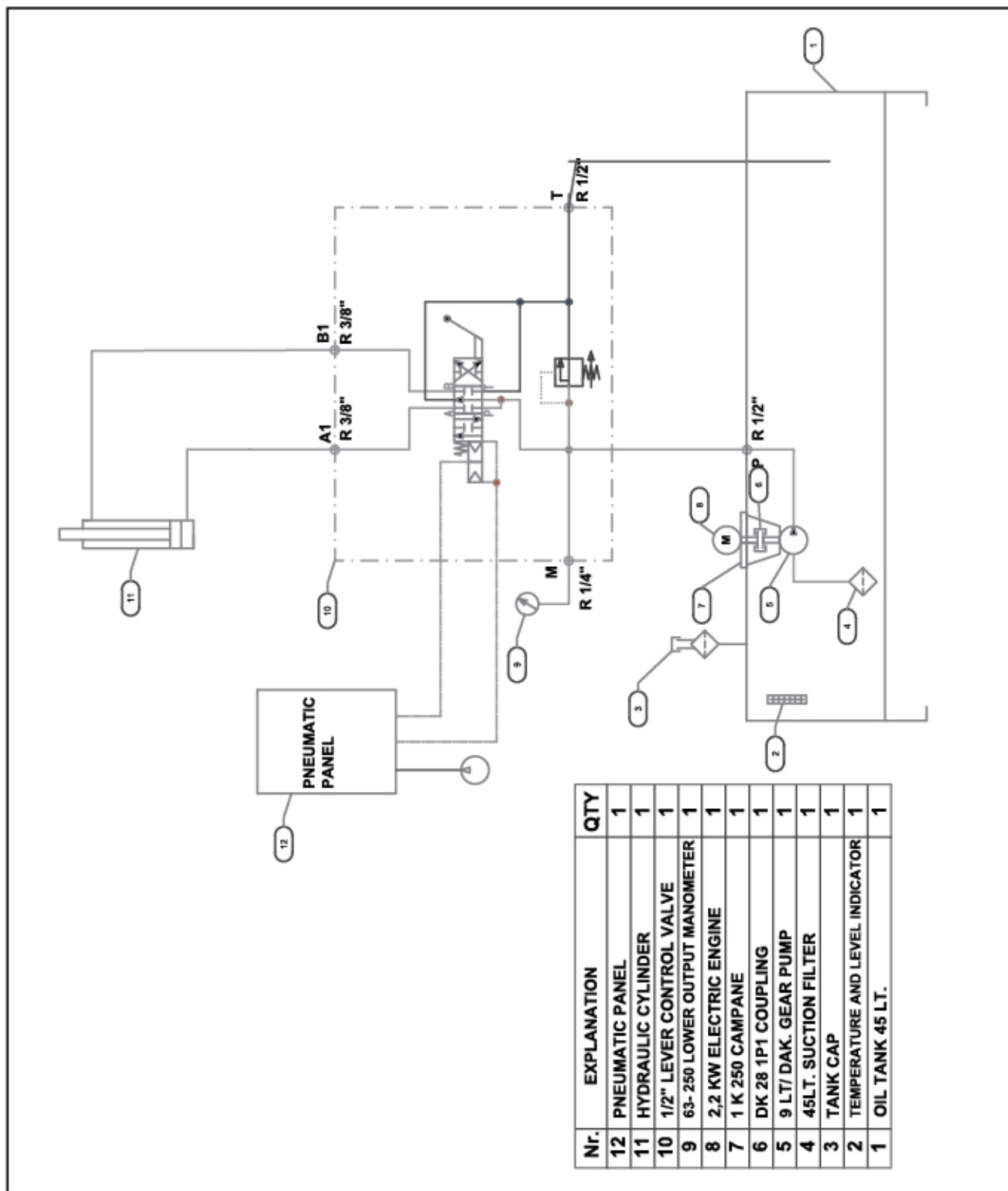

# SPARE PARTS LIST

## General Overview

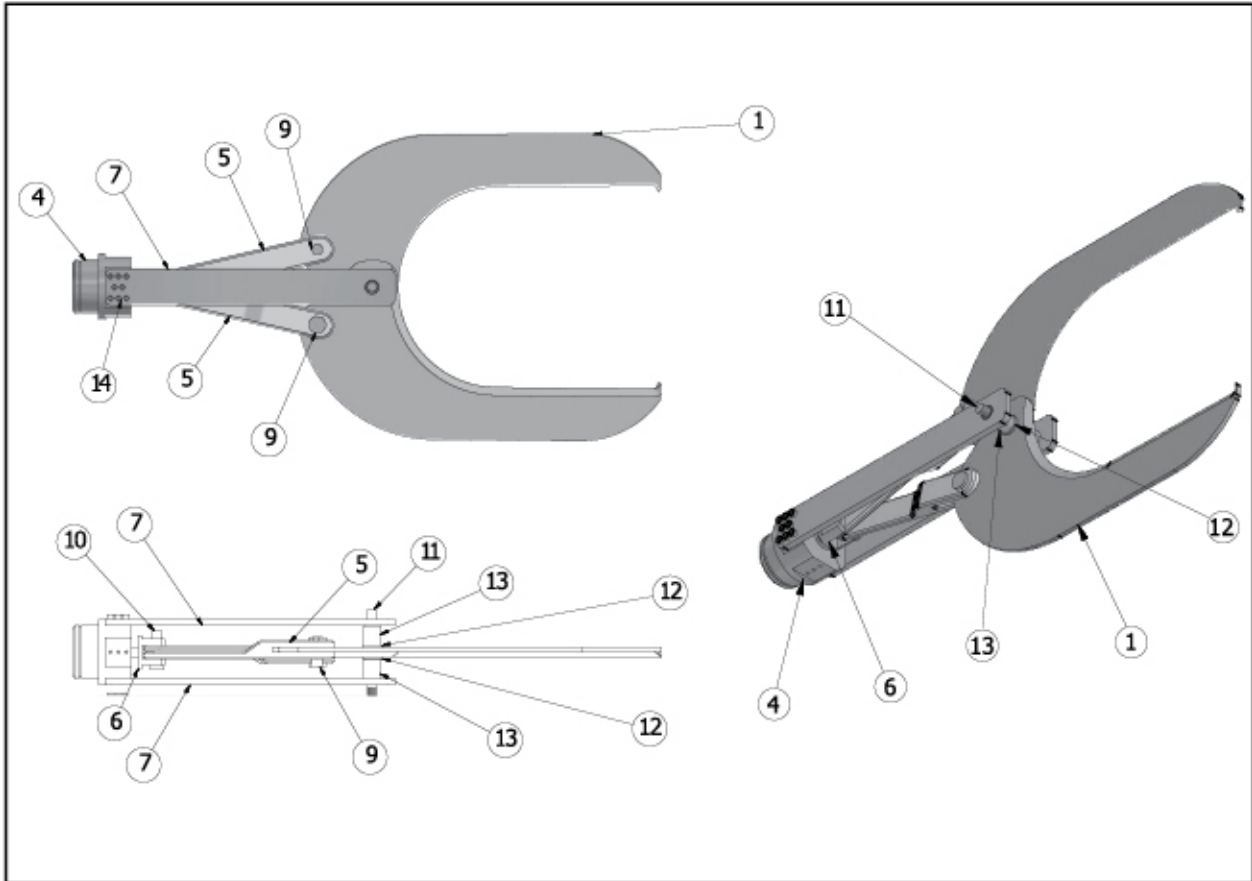

PARTS LIST		
ITEM	QTY	PART NUMBER
1	2	Blade
2	1	210.212.3100
3	4	Bushing 14x20x9
4	1	210.212.3300
5	2	210.212.4200
6	1	210.212.6000
7	2	210.212.2000
8	4	Bushing 16x20x79

PARTS LIST		
ITEM	QTY	PART NUMBER
9	2	Arm Pin
10	1	Clevis Connection Pin
11	1	Bushing 16x20x9
12	2	SKF_WS 81103
13	2	Bushing 16x25x30.25
14	8	DIN 912 - M6 x 10
15	1	handle

## CM-900 ENGINE LABEL



**CEMSAN MEZBAHANE SİSTEMLERİ A.Ş**  
Saray Mah. 4.Cad. No:49 K.Kazan-Ankara- TURKEY  
+90 312 801 0 222 info@lalesaws.com

PRODUCT NAME / ÜRÜN ADI : QUARTERING AND BREAKING SHEAR  
ÇEYREKLEME MAKASI

MODEL: CM-900

AIR PRESSURE/HAVA BASINCI: 6 bar

HYDRAULIC PRESSURE/BASINÇ: 180 bar

PRODUCT YEAR/ÜRETİM YILI:

SERIAL NO/SERİ NO:



MADE IN TURKEY

## TECHNICAL SPECIFICATIONS

### Physical Specifications

Weight	Scissor Clearance	Closing Speed
24 kg	300 mm	5 sec

### Pneumatic Inlet

Working Pressure
6 Bar

### Hydraulic Inlet

Pressure
180 Bar

**Type:** Blade Opening Front

**Drive:** Hydraulic

**Control:** Pneumatic Dual-Handle Anti-tie-down

**Cutting Speed Under Load:** .1 second

Manufacturer **Lale Cutting Tools** Ankara/Türkiye

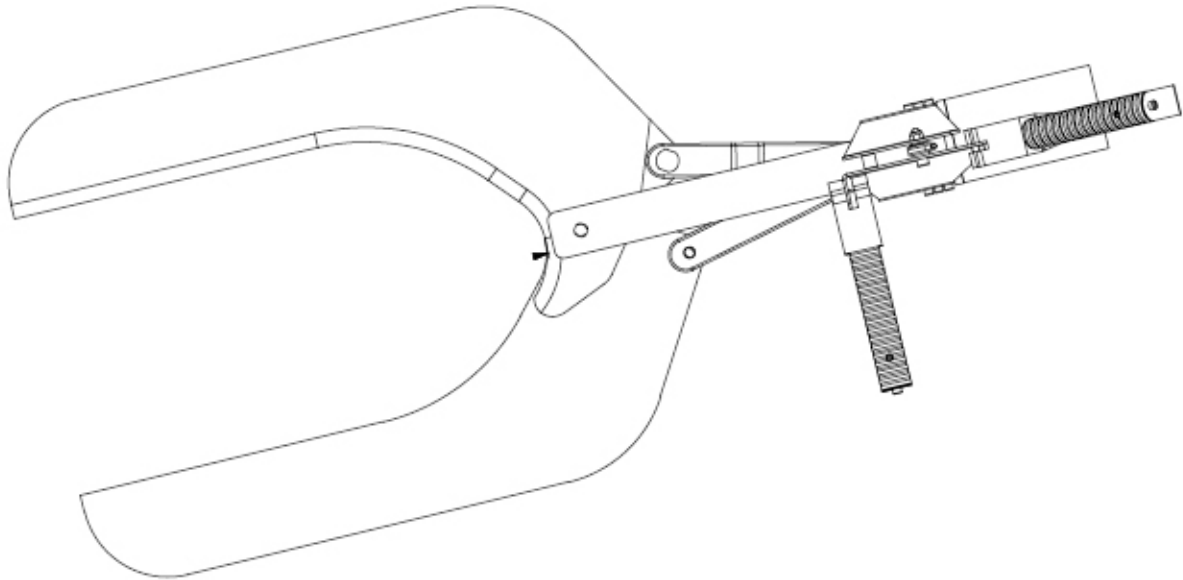
**SAFETY PRECAUTIONS**

It is essential that the following safety measures should be observed when operating the hydraulic cutting machine. Minors and untrained persons should not have access to the machine. Check the machine for any damage. Service the machine with care. The workplace must be kept clean with care. Wear suitable work clothes. Make sure that you stand securely. Install the machine in accordance with regulations. Switch off the main switch or disconnect the power supply

## CM-900 TROUBLESHOOTING

FAULT	POSSIBLE CAUSES	RECOMMENDED ACTIONS
Noisy operation	Blade connections are loose	Check the shear mounting bolts.
Insufficient cutting force	The shear is dull; the balancer pulling force is improperly adjusted	Replace the shear with a new one and readjust the balancer pulling force.
Shear does not cut at all	The shear is dull	Check the cutting depth of the shear.
The cutting blade sticks to the meat	The cutting blade is incorrect, dull, or deformed	Inspect the blade and replace it with a new one.

## CM-900 MAINTENANCE INSTRUCTIONS

### A - DAILY SAFETY CHECKS

- Check whether all parts are in proper condition by visual inspection.
- Check that all moving parts are correctly positioned.
- Check that the shear is properly installed.
- Check the balancer connection and pulling force by testing.

### B - DAILY CLEANING OF THE AKM-130

- The shear must be cleaned every day. Keep the shear clean.

### C - MAINTENANCE AND TROUBLESHOOTING

- In order to ensure a long service life of the shear, regular inspection, cleaning, and periodic maintenance must be carried out.

### D - MAINTENANCE INTERVALS

- Daily, weekly, monthly, and six-month inspections are recommended.
- The grease in the gearbox should be replaced every six months. The grease used should be Epro 0 semi-fluid grease.

### E - MALFUNCTIONS, CAUSES OF MALFUNCTIONS, AND REQUIRED ACTIONS

- In case of noise, unusual sound, vibration, or any abnormal condition that may occur during the cutting operation, please refer to the table below.

**APPLICATION/DESCRIPTION**



Example of correct use of the Quartering and Breaking Shear

**CORRECT USE**

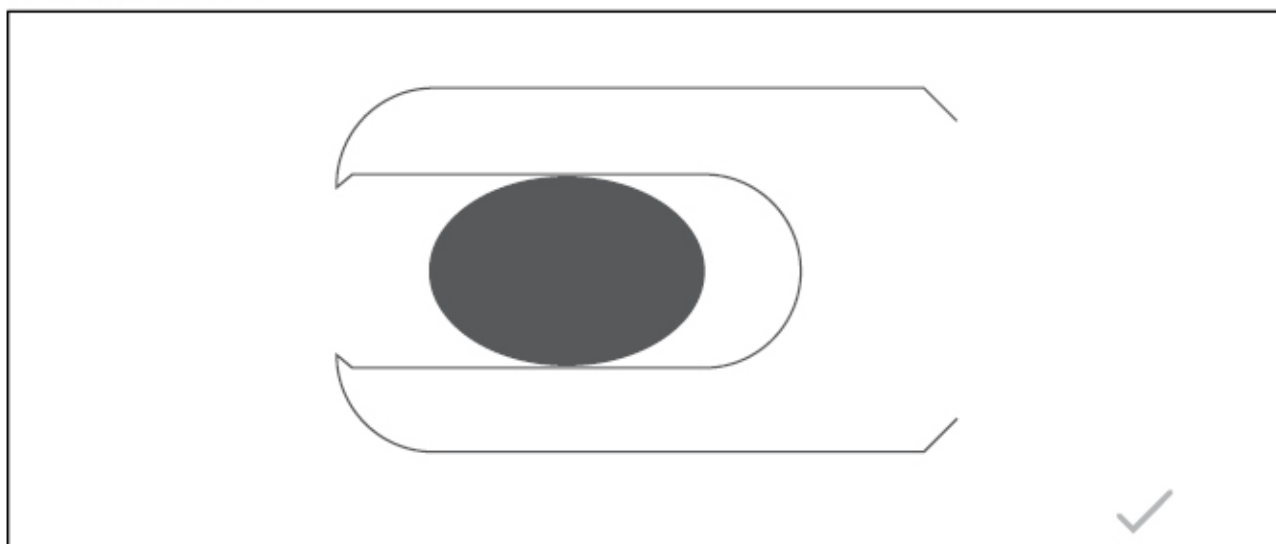

**WRONG USE**

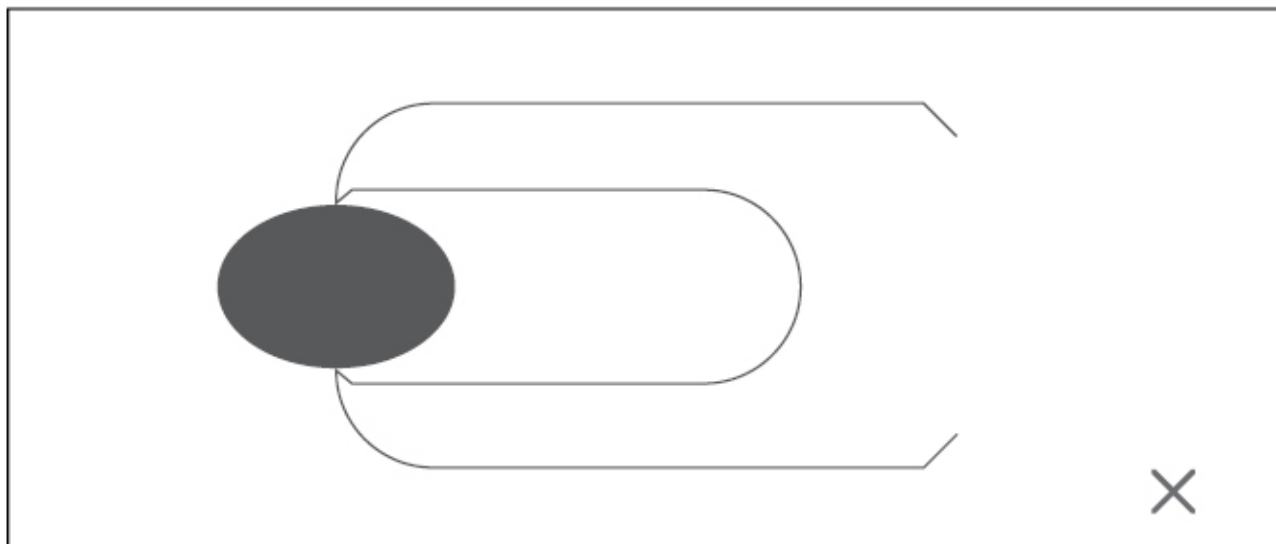



**APPLICATION/DESCRIPTION**

- Cutting cattle and calves body
- Cutting sheep body
- Cutting pigs

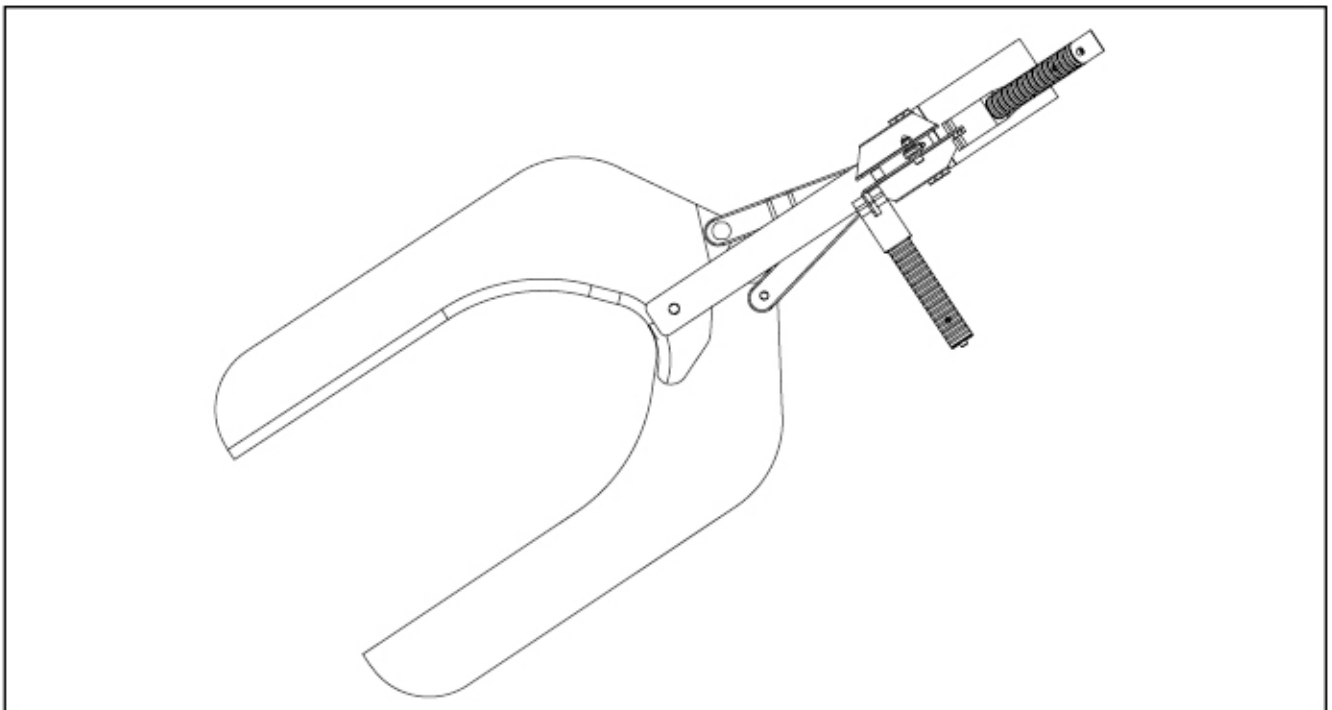

**APPLICATION/DESCRIPTION**



New developed  
hydraulic quartering shear machine

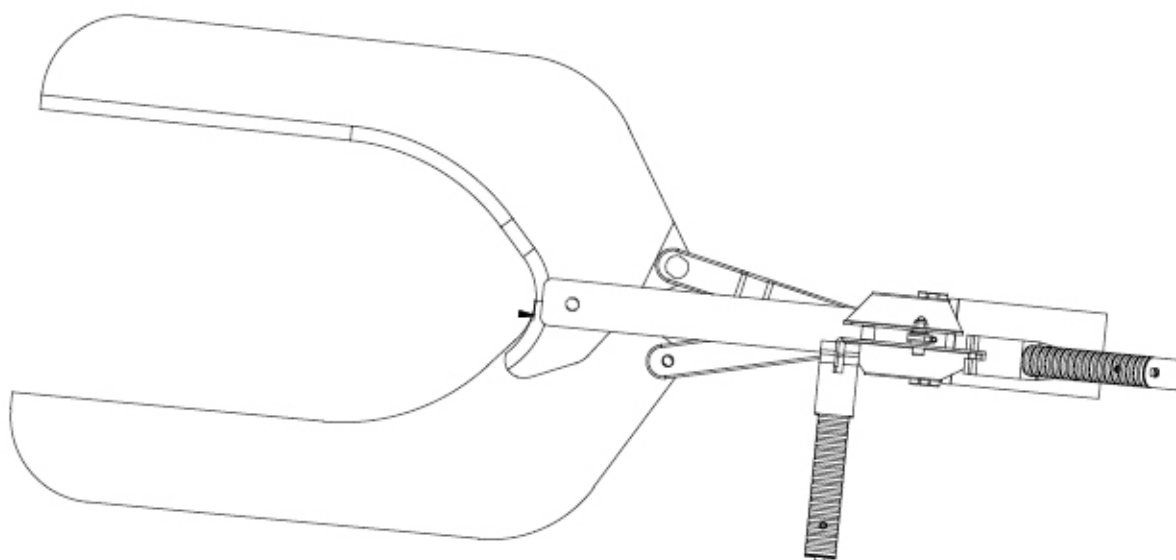

Lever shear with two movable blades

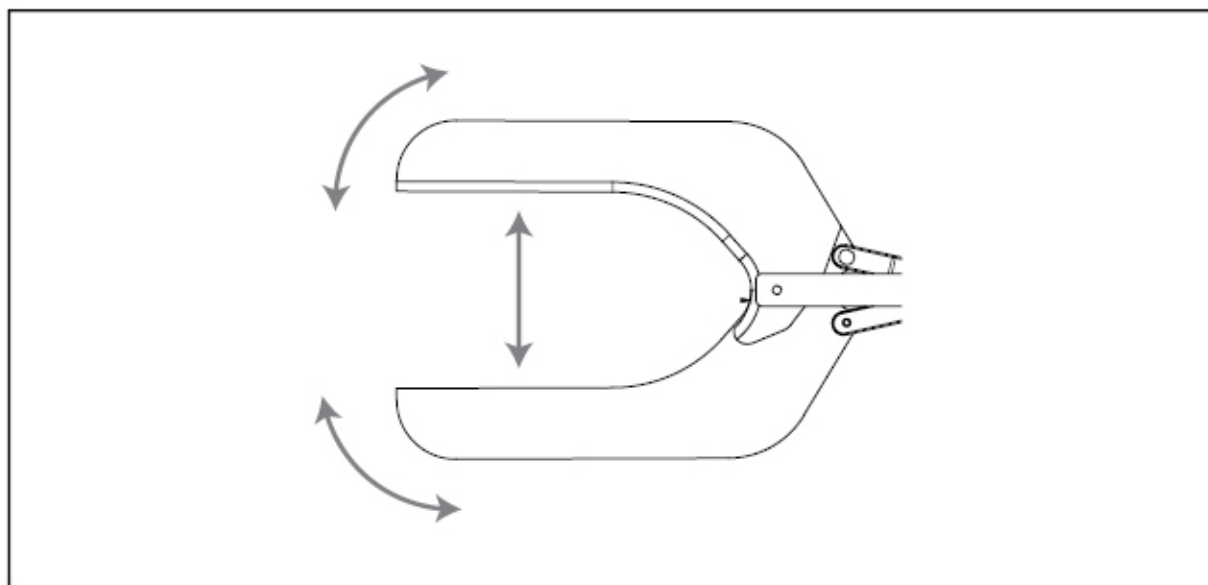



**APPLICATION/DESCRIPTION**

Large opening width

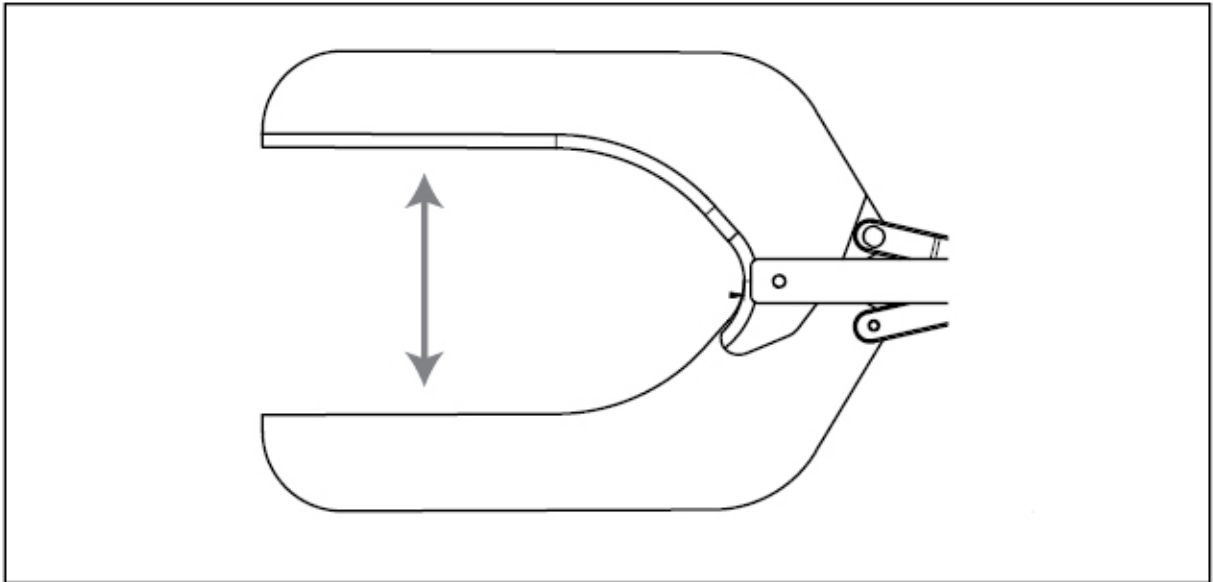

Rear handle fastening able to swivel around end of cylinder

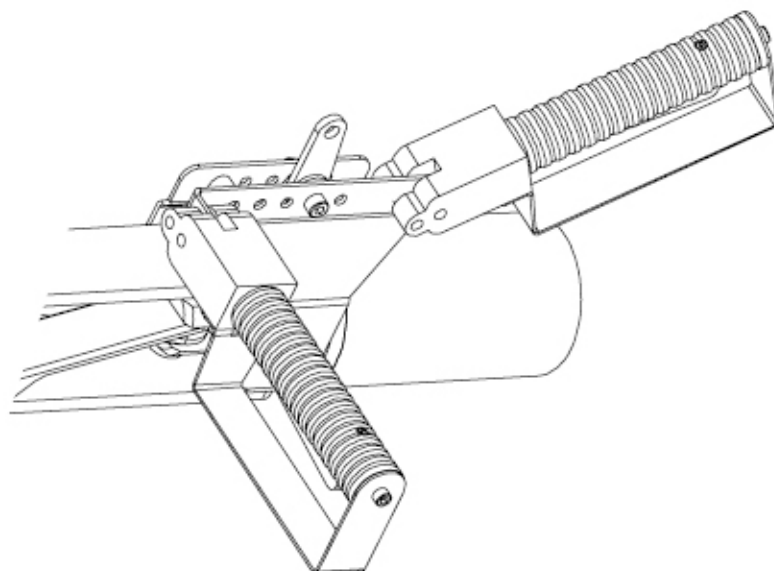

**APPLICATION/DESCRIPTION**



Long lasting blades

**HIGH**  
Durability

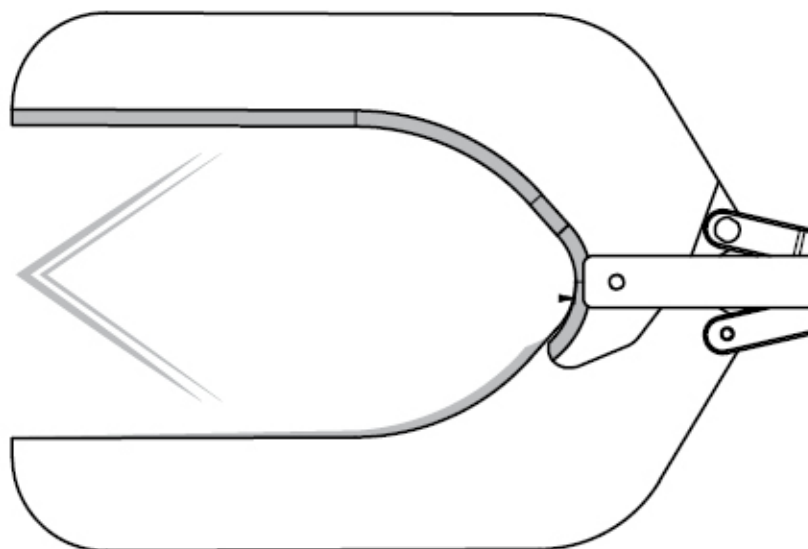

Easy and fast to clean and sterilize be due to smooth finishes and design.  
Safe operation be due to dual safety control (anti-tie-down)

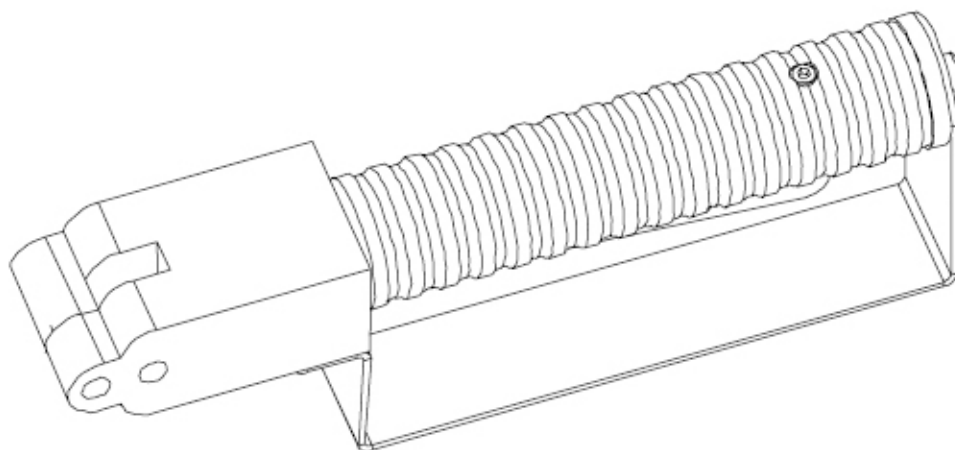



## APPLICATION/DESCRIPTION

Totally waterproof  
Optimised ergonomics

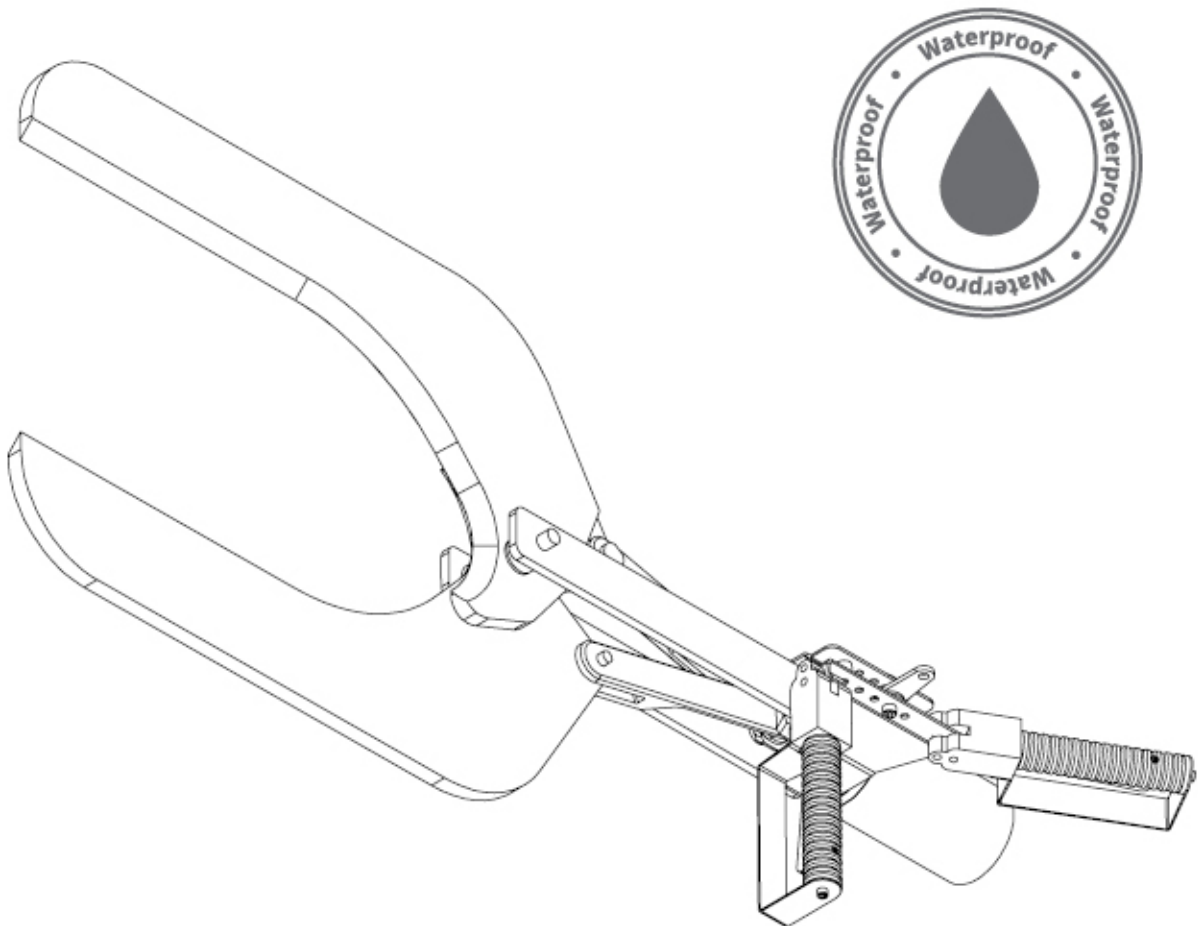

## INSTALLATION / OPERATING PRINCIPLE

### ■ Installation

- Fasten the balancer with safety chain high enough and append the shear.

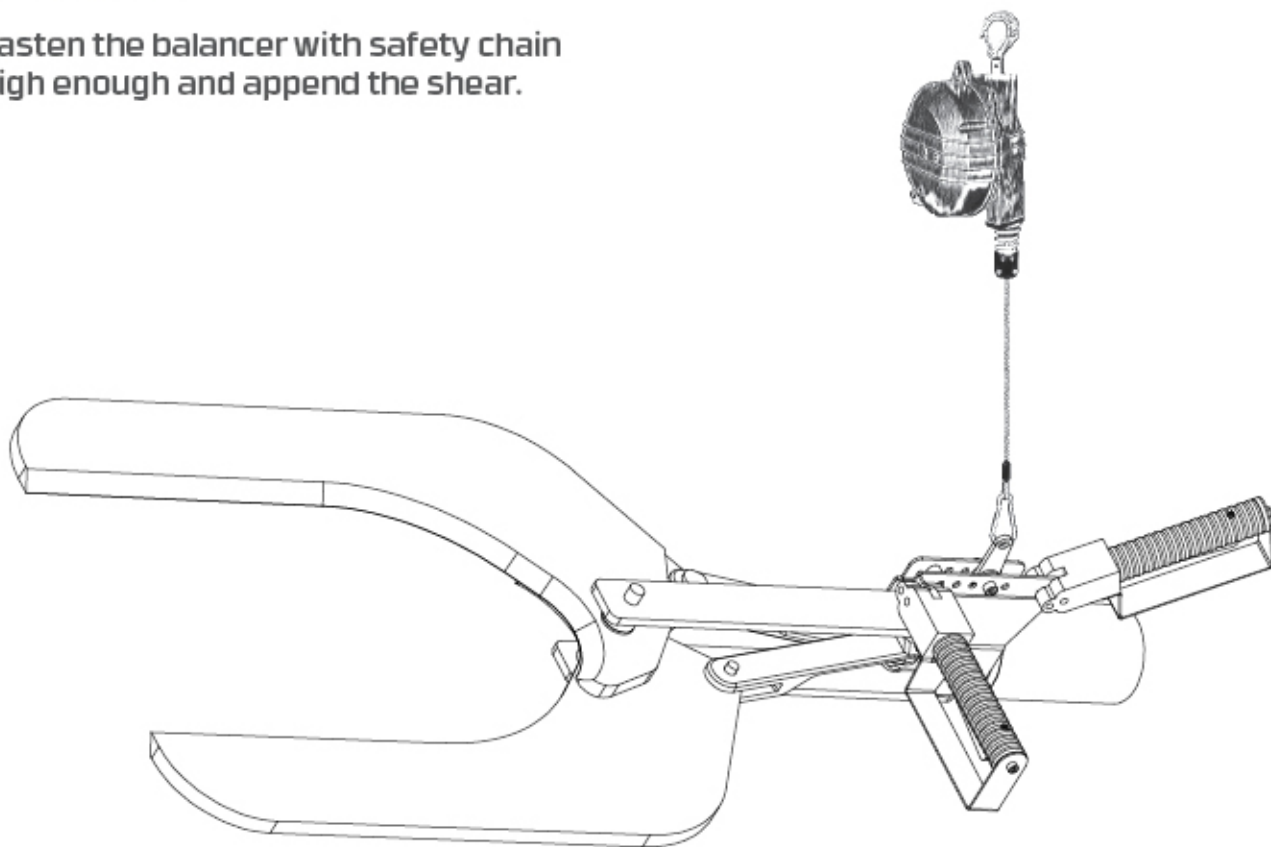

- Connect hoses to the shear by means of fast seal couplings.
- Put the hydraulic unit fill SAE 68 hydraulic oil.
- Do not readjust any pressure setting, these have been preset at factory.
- Connect hydraulic hoses to port on hydraulic unit.
- Start power unit at the main switch.
- Connect air line to unit the pressure must be at least 6 bar.

## INSTALLATION / OPERATING PRINCIPLE

### ■ Operating Principle

- Lift the open shear to the body.
- Press the levers of both handles to the stop simultaneously and hold them-do not use any excessive strength.
- After completion of the cutting event let the leveres off-the shear opens automatically.

### ■ Maintenance

- The cutting success depends on the sharpness of the knives mainly.
- The knives must be sharp.
- Clean the shear after work end lubricate the pivot bolts and grease the blades with food grease.

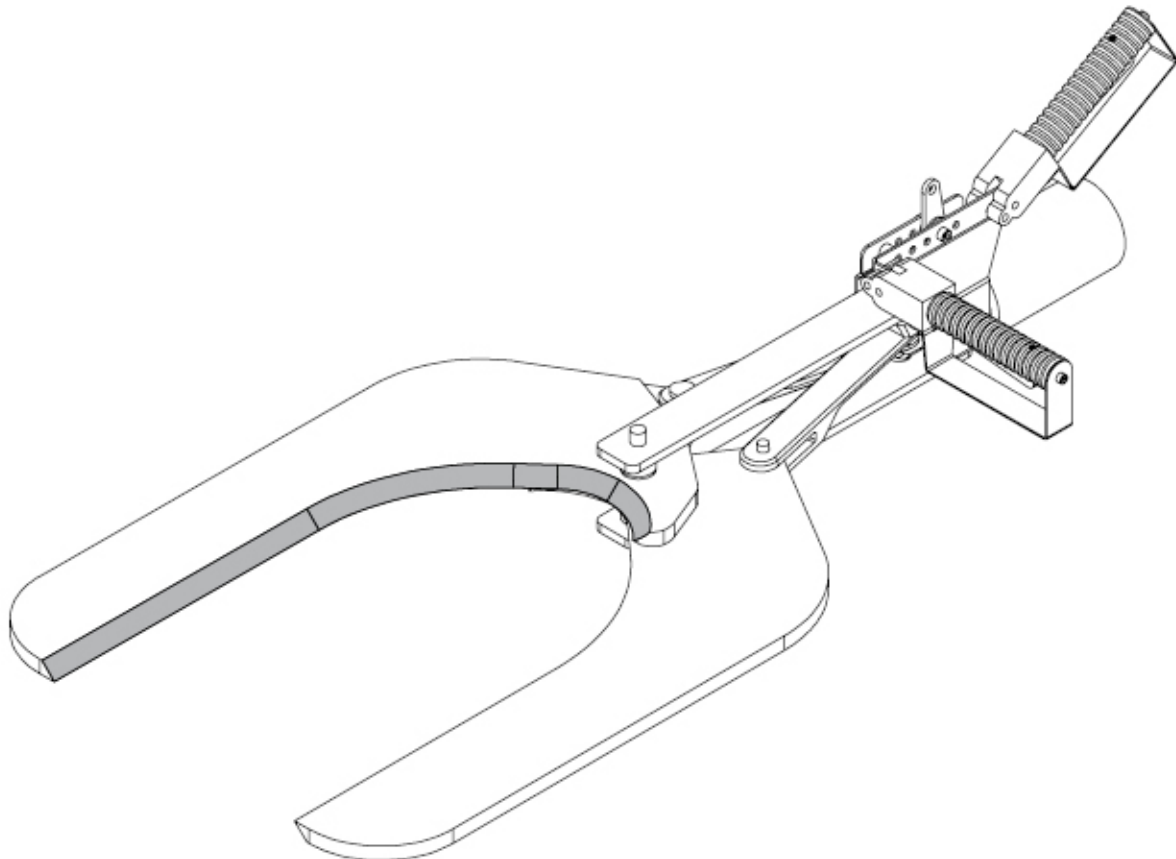

# CM-9000

QUARTERING AND BREAKING SHEAR



CUTTING TOOLS



Saray Mahallesi, 4. Cadde No: 49  
Kahramankazan / Ankara / TÜRKİYE  
+90 801 02 22 • info@lalesaws.com

