

CARCASS SPLITTING SAW

USER MANUAL

KBT-650

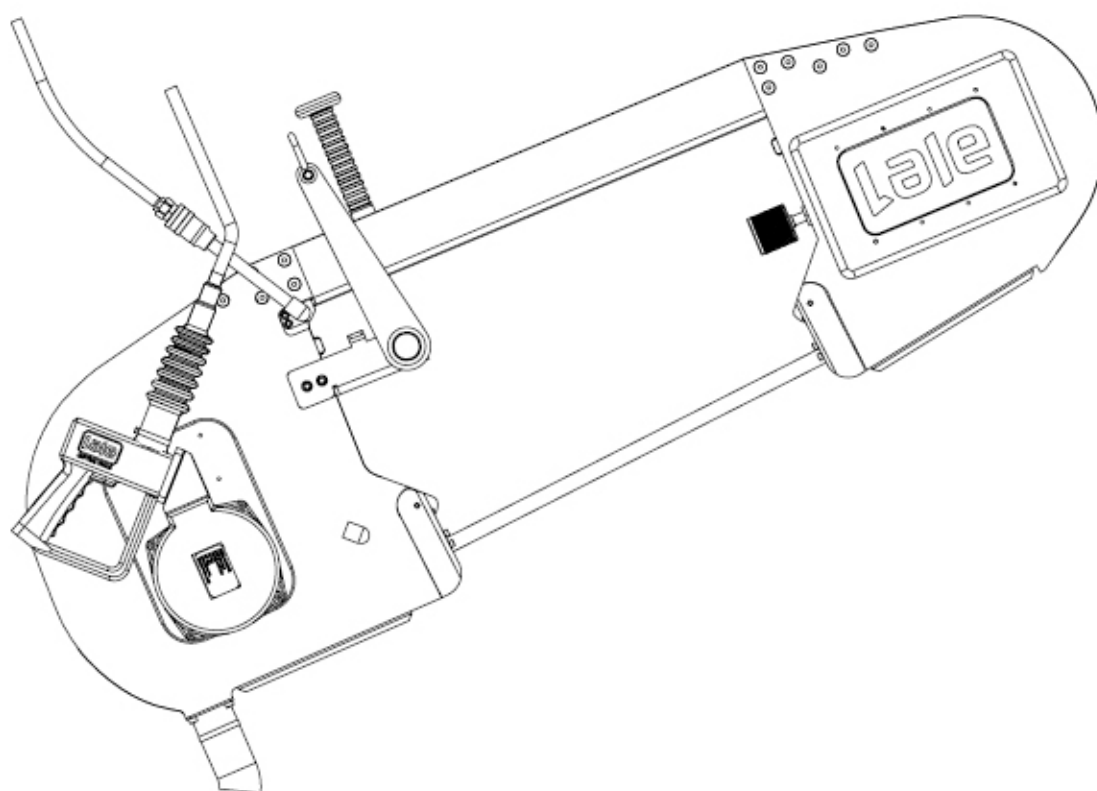

COMPANY INFORMATION

Registered Trademark: **LALE**

Manufacturer Firm: **CEMSAN A.Ş.**

E-Mail: **info@lalesaws.com**

Web Address: **www.lalesaws.com**

FACTORY

Address: **Saray Mahallesi, 4. Cad. No: 49**
Kahramankazan/Ankara/Türkiye

Phone Number: **+90 312 801 02 22**

**DYB-110**PNEUMATIC
DEHIDER**AKT-280**FOOT CUTTING
SAW**DAT-230**BRISKET
OPENING SAW**KBT-650**CARCASS
SPLITTING SAW**CT-280**QUARTERING AND BREAKING
SAW**AKM-130**FOOT
CUTTING SHEAR**CM-900**QUARTERING AND BREAKING
SHEAR

TABLE OF CONTENTS

About the Manual	4-10
Transferring and Storing	11
Assembly and Engaging	12
Assembly of the Balancer	13
Carcass Splitting Saw	14
Electrical Connection 1	15
Electrical Connection 2	16
Electrical Connection 3	17
Spare Part List	18-30
KBT-650 Engine Label	31
Electrical Panel	32
Electrical Socket	33
Saw Maintenance Instructions	34
Saw Trouble Shooting	35
Safety Measures	36
Implementation/Definition	37-41
Technical Properties	42
Installation/Working Principle	43-44
Compatible "Premium" Bandsaw Blade	45
Compatible Balancer	46
Compatible Disinfection Cabin	47

ABOUT THE MANUAL

■ This manual has been prepared for you to work quickly and safely.

The manual is a component of the machine, and it includes the following:

- Important information
- Usage of the machine in a safe and effective way
- Cleaning and disinfecting for maintenance

Examine the manual carefully before operating the machine.

Be sure that you obey the safety instructions completely.

Always keep the manual near to the machine.

The manufacturer will not take any responsibility for the user errors

To Whom Do We Appeal?

This manual is a necessity for the owners of slaughterhouse, experts, butchers, apprentices, and technical personnels. It has been prepared for the people who have basic know-how.

Conservation of The Manual

This manual is a part of the machine, and must be accessible everywhere!

Operating and maintaining personnel shall be instructed that they must keep the manual with the machine all the time during the service life of the machine.

Order Items

Various parts of this manual enables you to define the specific order items and meaning of the text.

The manual includes reading parts, symbol explainings, numerations, instruction steps, step by step series with a particular order, references to another parts, technical schemes, important supplementary infos, or details regarding to usage of the machine.

About The Manufacturer Firm

CEMSAN Slaughterhouse Systems has been supplying the most modern slaughtering and integrated meat processing facilities such as slaughtering equipment, meat processing equipment, storage, cooling rooms and meat handling systems for slaughterhouses that slaughter cattle and sheep for 33 years. As a result of our R&D activities carried out for many years, we are pleased to present LALE Cutting Tools to all of our customers in accordance with EUROPEAN QUALITY STANDARDS.

As a leading brand in slaughtering technologies with over 550 slaughterhouse and meat processing plant references, it attaches utmost importance to hygiene, ergonomics, safety, quality, animal welfare and



ABOUT THE MANUAL

butcher health in every production. It always prioritizes customer satisfaction, and takes immediate action against all problems that may occur with our quality technical service. We are able to meet all kinds of cutting requirements of all slaughterhouses and meat processing plants of all capacities with the highest standards, including production, assembly and after-sales services with our wide range of products.

Responsibilities and Warranty Terms

All the information and instructions relating to the operation and maintenance of the machine in this manual are presented by considering our experience and knowledge. LALE Cutting Tools refuses any responsibility for the demands which are not covered by guarantee, except for the demands legally indicated and agreed on by both buyer and seller.

Significant Points for Your Safety

It is explained in this part safety precautions and tools for safety. Be sure that you read and understand the following safety instructions before operating the machine. This part aims to lead you about safety issues regarding to the usage of machine.

The original version of the manual has been written in Turkish. In case of any inconsistency or contradiction between Turkish and English version, The Turkish version shall be valid.

Warranty shall be null and void in following situations:

- When there is disobedience to the information in this manual.
- When the machine is used in contrary to its purpose.
- Usage of spare parts or part unapproved by LALE Brand
- Changing parts of other materials without getting approval of LALE brand's managers in advance.
- When the machine is not operated in a proper way or by untrained personnel.
- Any damage occurrence while cutting.
- When the safety device or equipments are removed, taken off, or substituted with another unapproved material.
- When the machine is not cleaned properly or professionally.
- When the machine is exposed to chemical or mechanical stress.
- When the maintenance is made in a wrong way or maintenance periods or instructions is neglected.
- Spare parts

In specific situations, the written approval shall be gotten by discussing with LALE brand managers in case some modifications or settings are desired.

ABOUT THE MANUAL

Warnings to Be Taken Seriously for Safety



Warnings against sharp-edged machine parts. Danger of cutting, injuring, or chopping the limbs.



Warning against rotating blade saw and saws in common.



Warning against dangerous electric potential.



Warning against common hazards.



Warning against hot surface.



Danger for crushing your hand or fingers

Work Safety Equipments to Be Abided By



Put on enduring and covered-closed shoes.



Wear protective gloves.



Wear eye-protecting equipments.



Wear hearing conservation.



Wear hair net or casque.



Wear protective uniform



Forbidden Actions



Use high pressured purifier for cleaning

Safety Signs on Machine



Warning for the saw's direction.



Warning against cutting.



Warning against dangerous electric potential

ABOUT THE MANUAL

About The Conservation of The Manual

Manual must be always accessible by operating and maintaining personnel during the whole service life of the machine. For this reason, keep the manual near to the machine all the time!

Responsibilities of Business Manager

Keep in mind that in an establishment dealing with the meat market, it is obligatory to give permission only to the older than 18 year-old and to the people who have insurance and are familiar with their work, in accordance with the regulations and rules relating to health and safety. Even when they have completed their occupational training and read safety instructions, their safety must be examined by an official.

Facility manager is responsible for providing training of each employee working in operation of the machine in most effective way. Trained personnel shall work on machine under only the following circumstances:

- The machine must be completely functional.
- Safety points must be checked regularly.
- Business managing director must provide the density of the lighting to be at least 500 lux
- Work places must be at least 1,5m wide, ensure at least 1 m depth per a personnel to enable the personnel to move together with the machine.

ABOUT THE MANUAL

- It must be inspected that the personnel using the machine has a work uniform and protective equipments coherent to the OHS regulations.
- Surface material of the work platform must not be wet, and not carry the risk of slipping on oily surface.
- The place where the machine is must be suitable for hygiene and work place rules.
- Be sure that on the area/platform, the escapeways and/or their functions are not blocked at the moment of accident.

Responsibilities of Employees

- Operating personnels must be informed and trained by the employer properly.
- The personnel must be the one who read and comprehended the safety instructions and are trained, know operating the machine.
- The personnel must be familiar to the manual.
- They must have completed the legal trainings relating to the accident prevention regulations and current OHS.
- Along with assembly, maintenance, and repair, problem solving must be done only by qualified personnel. They must have knowledge about warranty conditions.
- The personnel must keep the work place tidy and clean. Untidy work places and areas may cause accidents.
- The personnel must wear personal protective equipment provided for them.
- The child, young, and untrained must be kept away from the machine.

Electric Safety

About The Purpose of The Machine's Usage

Carcass Splitting Saw KBT-650 is a striped saw used in cutting the carcass into two half for cattle.

This model has the following features:

- Manually saw stretching system
- Special covered blade manuals
- Integrated washing system within the saw
- Water hose kit
- Electrical-water-valve

The points which have huge significance:

- It can be operated with 380V electric energy.



ABOUT THE MANUAL

- It can be run by only one operator.
- It can run only when specific safety devices are mounted.

Any kind of usage except for splitting cattle carcass is accepted as contrary to the aimed usage and sale rules.

Reminders for running usage of the machine:

- Obedience to safety instructions.
- Conducting the maintenance and repair works properly.
- Cleaning the machine regularly.
- Using the original spare parts.
- That the personnel have training of how to use the machine.

Warning Against Misusage

- Use the machine properly only for its intended purpose. In an uncertainty, consult to manufacturer.
- In no way, do not use the machine for cutting the materials such as wood, rock, plastic.
- Do not extend the cables and connection lines in the machine.
- Do not use the machine if the safety devices do not run.
- Do not use a machine with higher than 380 V in cutting area.

Any other usage apart from the ones indicated in "About the intended purpose of the machine" is accepted as contrary to the intended purpose. LALE Brand or the main manufacturer firm CEMSAN A.Ş. will not take any responsibility for damage or injure. The risk causing from inappropriate utilization belongs only to the user.

About The Permanent Risks

Carcass Splitting Saw KBT-650 has been designed in accordance with the highest technology, and general safety and healthy rules valid in Republic of Türkiye and the European Union.

However, it is still subject to hazards which can not be eliminated with the design precaution:

- Danger of wounding in fingers and hands.
- Danger of injuring yourself due to the meat cut and bone pieces.
- Danger of injuring eyes.

ABOUT THE MANUAL

- Breaking or flouncing of saw's blade.
- Danger of electricity arising from usage of inappropriate connection cables.

Despite all the precautionary measures, remind that undistinct residual risks may be permanent. You can minimize these risks by paying attention to the safety instructions in each part's beginning and to taking the instructions in the manual as a whole.



ATTENTION!

There are sharp-edged machine parts.

Danger of cutting.

- Never put your hands near to the movable machine parts.
- Keep your hands away from the saw's blade or blade.
- Wear protective gloves for your own safety.



About The Electrical Danger

During all the maintenance and repair works, take the machine out of electrical power supply.



About The Heat Dangers

Your skin may burn when you touch it during utilization of the product due to engine's heating.

In case of a necessity to touch, hold the machine only from its handle, and wait for it to be cold. Never touch it before it is cold.



About The Mechanical Dangers

Your fingers and hand may be stuck or crushed during the process.



You will have a great risk due to the movements of the machine (twisting and kicking) while it is working.

Be careful while the machine is running. Try to stand stable!

TRANSFERRING AND STORING

Our machines are designed for the shipment via motorised truck, train, plane or vessel. Shipment may be separately or in multiple packages. Our machines have gone through testing process at our factory and been inspected thoroughly before they are sent out. This inspection means that the machine meets the datas given and it works accurately. The machine may get damaged despite of all the caution.

Taking The Machine Out Of It's Package

The machine is ready as compliant with the installation, and installation rules while you open the package of the product. Installation can be done as convenient with the necessary installation articles.

As per our quality policies, the original package of the machine is made of recyclable material. Product package can be given to the places where the recyclable materials are collected. Thank you for being sensitive to environment.

- Remove all the packing materials and throw them away properly.
- Remove all the protection materials placed in the package.
- Check whether there is a shipment damage in the machine.
- Monitor the machine for inspection at the first working-hours.
- Look out whether there is a fault at the first operating. In case of any, contact immediately with our firm. Do not ever interfere in the machine.

Conversation of The Machine

Be sure that you pay attention to the following notes for conserving the machine safely:

- Store the machine only in dry or places where will not have frost.
- Be sure that the machine is completely dry while storing the machine for a longer period of time.
- Conserve the machine in a way that it does not damage itself.
- Protect the machine against corrosion.

ASSEMBLY AND ENGAGING

The installation and connection of the machine shall be made by the operator. LALE Brand is not responsible for the damages occurring while the assembly is being made not by the authorised operator.



ATTENTION!

Active machine parts. Life-threatening.

- Before operating the machine, cut off it's electricity first and ensure it for not to be opened again by accident.
- Give permission only to the qualified electrician to work on dynamic and electrical components.



WARNING!

It may cause life danger and severe injury if unqualified and incapable personnel are employed.

- While commissioning, it requires to allow only the trained and authorised service personnel to operate the machine.
- Only certified electricians must perform workings on the dynamic and electrical components.



WARNING!

Sharp-edged machine parts. Danger of cutting yourself.

- Do not ever put your hands near or close to the moving machine parts.
- Keep your hands away from the saw's blade or the blade.
- Wear protective gloves for your own safety.

Personel Protective Equipment

Wear personal protective equipments during assembly and operating absolutely in order to prevent any injuring.



Protective gloves



Enduring and covered-closed shoes

ASSEMBLY OF THE BALANCER

Purpose of the balancer is to eliminate the constant weight of a tool during a vertical movement. It has been designed to be used by only one operator at one time manually.

It has been designed to be used in inner places with a temperature between of 5°C and 60°C. It is suggested that the load should be hung at the center of gravity in order for the product to be used.

In the models with locking tool, The device must be activated for stopping the bant (visible red indicator or closed padlock). Then, you must slowly manipulate the load till it is placed in lock hole (placed in about every 100 mm along the rope stroke). The balancers are in accordance with each regulations relating to workplaces.



WARNING!

The balancers need to be inspected and maintained at regular intervals in order to run perfectly in compliance with each regulations relating to workplaces.

CARCASS SPLITTING SAW

KBT-650

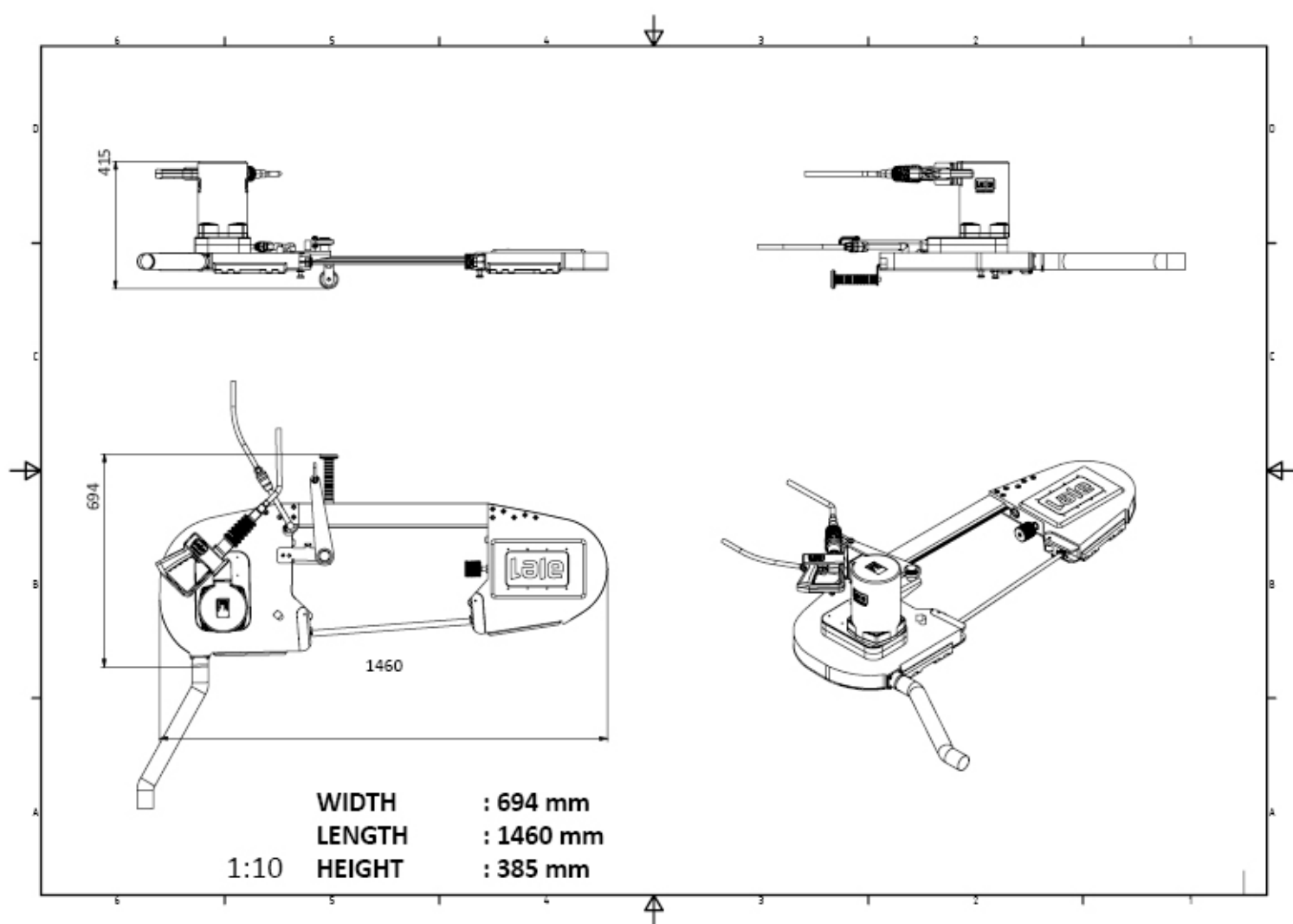

ELECTRICAL CONNECTION 1

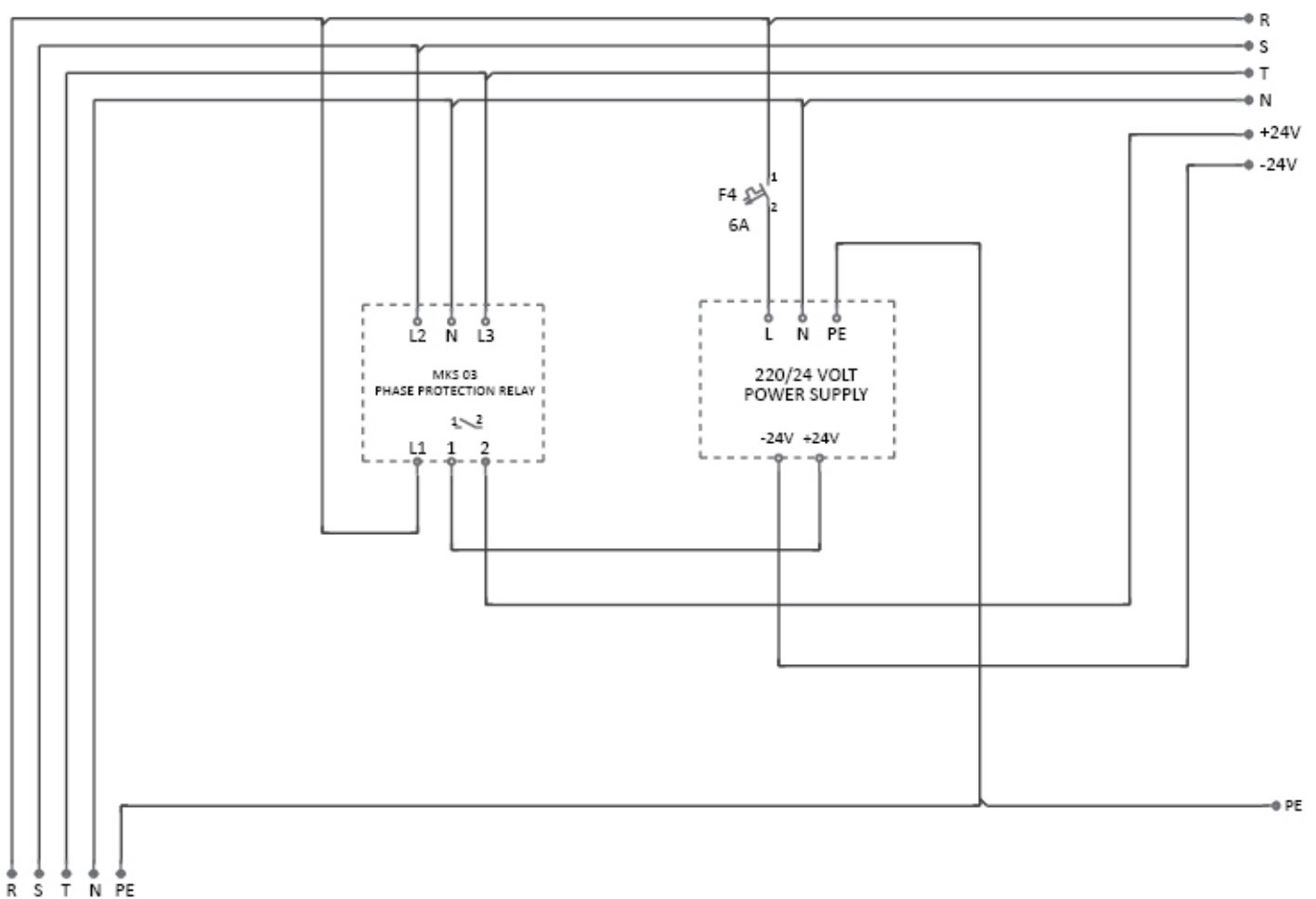

ELECTRICAL CONNECTION 2

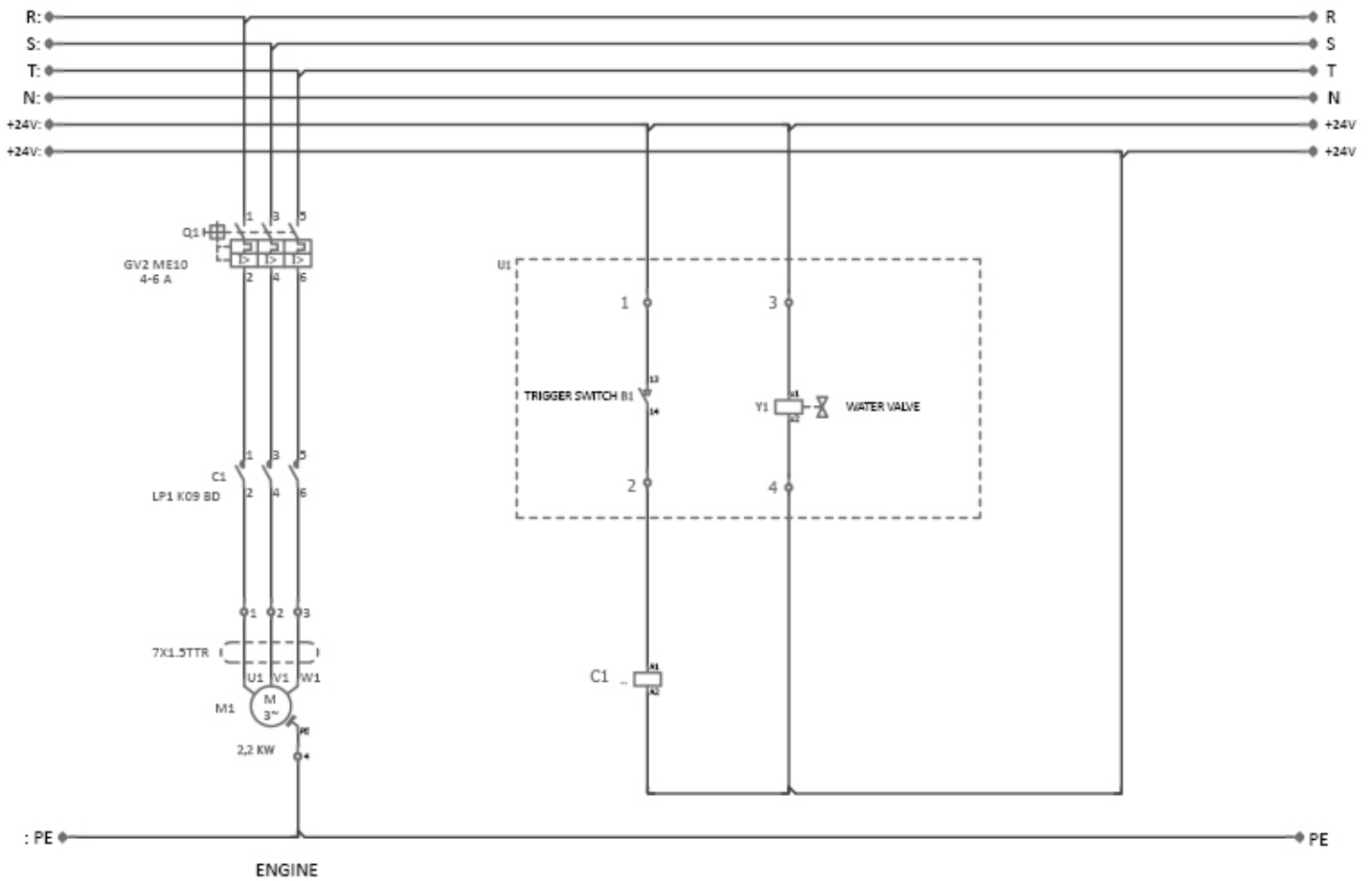

ELECTRICAL CONNECTION 3

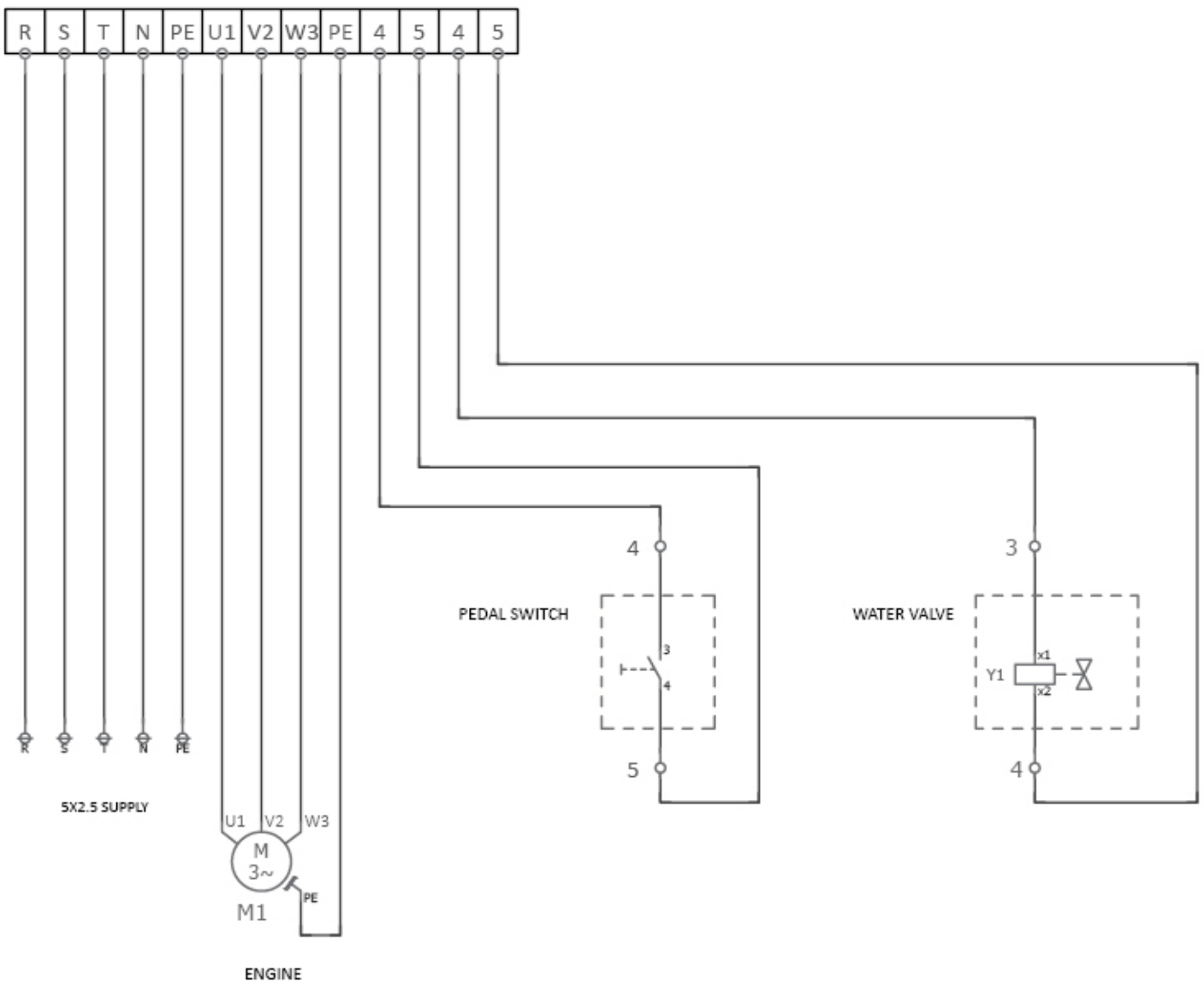

SPARE PART LIST

General View

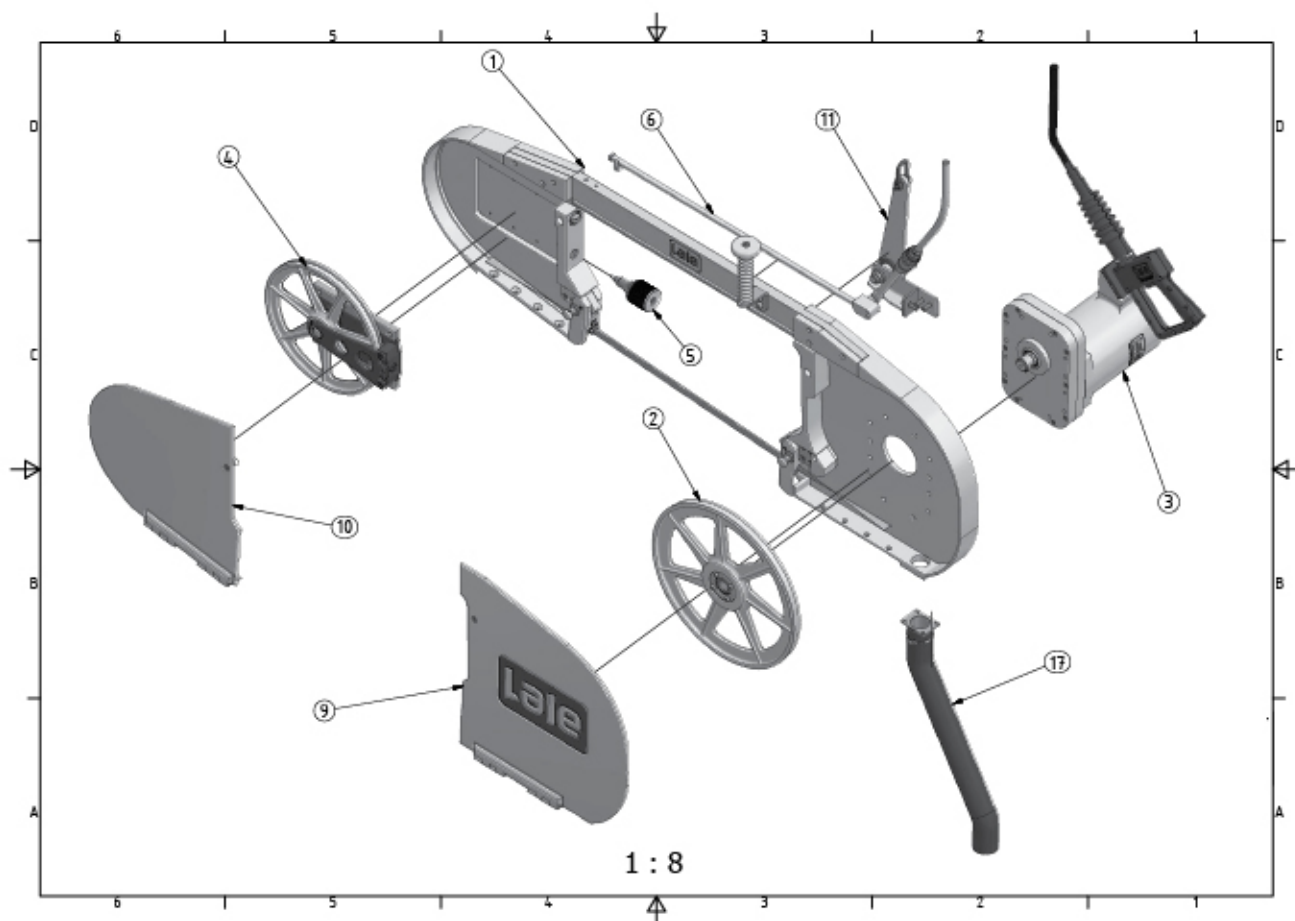

PART LIST

PART	PCS	PART NO
1	1	530.102.1000
2	1	530.102.2000
3	1	530.102.3000
4	1	530.102.4000
5	1	530.102.4100
6	1	530.102.5000
7	1	530.102.5003
8	2	530.102.6003
9	1	530.102.6100
10	1	530.102.6200
11	1	530.102.6500

SPARE PART LIST

Body Connection Diagram

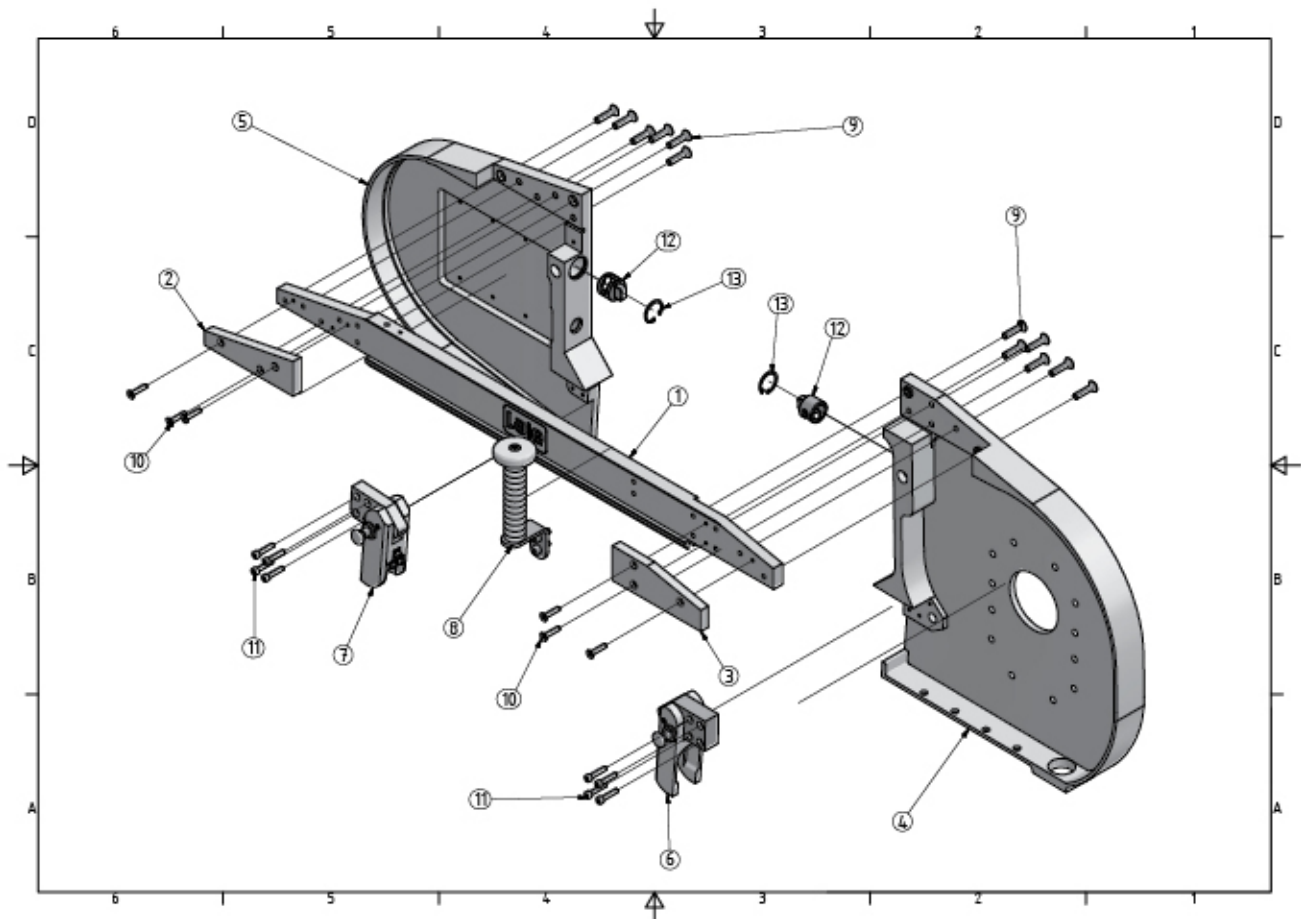

PART LIST

PART	PCS	PART NO
1	1	530.102.1001
2	1	530.102.1003
3	1	530.102.1002
4	1	530.102.1004
5	1	530.102.1005
6	1	530.102.1100
7	1	530.102.1200
8	1	530.102.1300
9	12	Bolt
10	6	Bolt
11	8	Bolt
12	2	530.102.6003
13	2	Ring

SPARE PART LIST

Rear Saw Lock Diagram

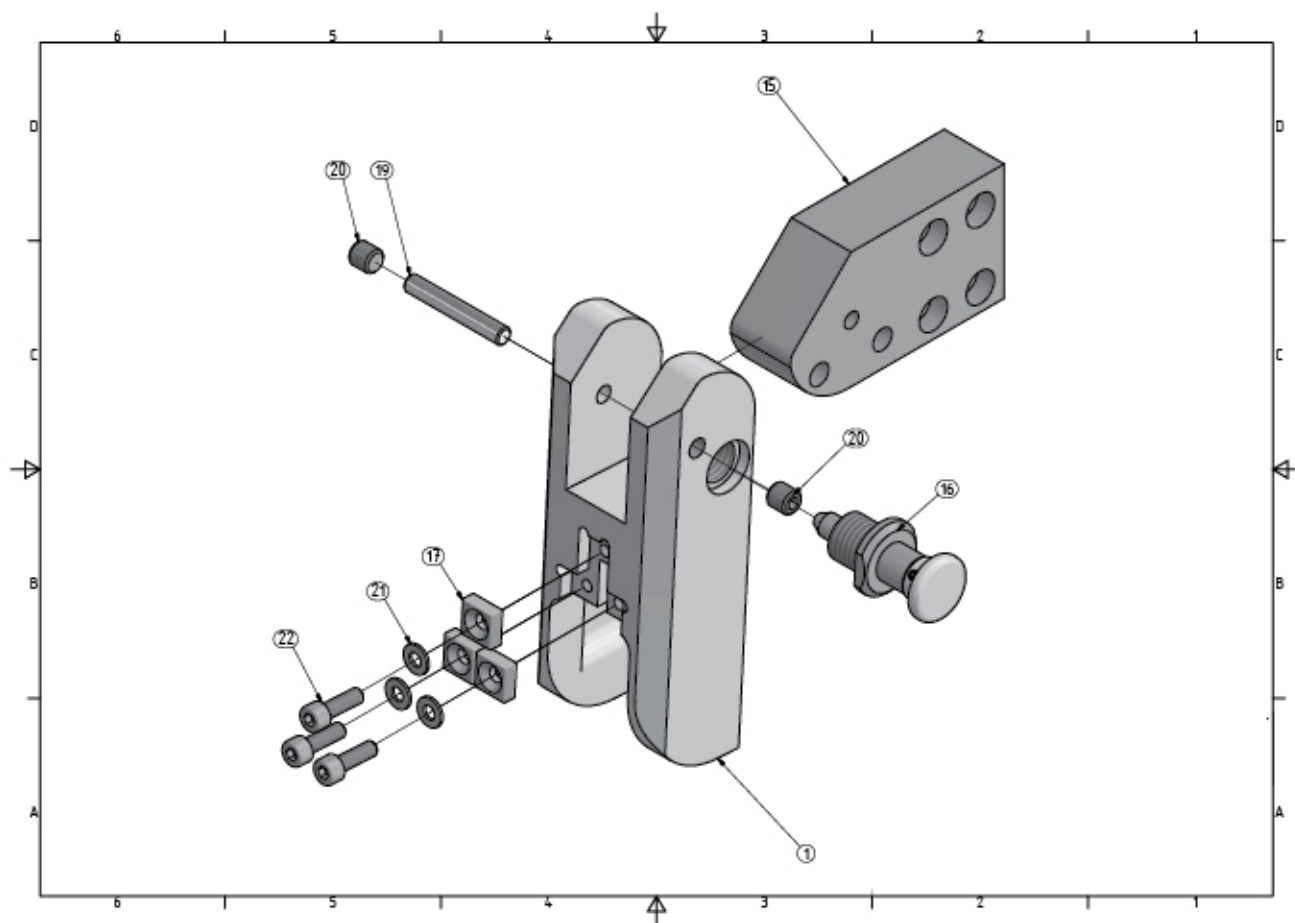

PART LIST

PART	PCS	PART NO
1	1	530.102.1101
15	1	530.102.1102
16	1	530.102.1130
17	3	530.102.1108
19	1	530.102.1103
20	2	Bolt
21	3	Shim
22	3	Bolt

SPARE PART LIST

Lock Spring Diagram

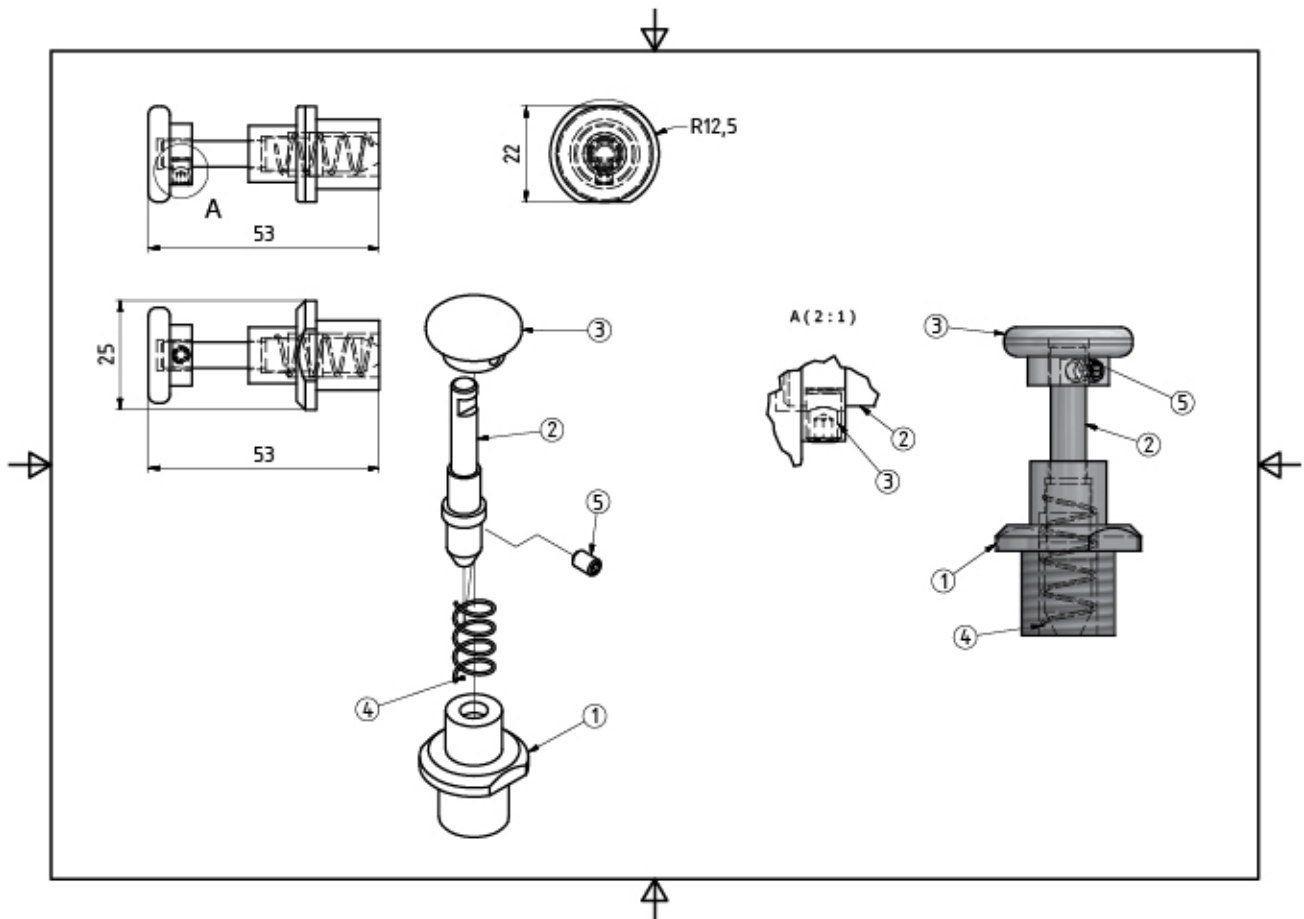

PART LIST

PART	PCS	PART NO
1	1	530.102.1131
2	1	530.102.1132
3	1	530.102.1133
4	1	530.102.1134
5	1	Bolt

SPARE PART LIST

Front Saw Lock Mechanism Diagram

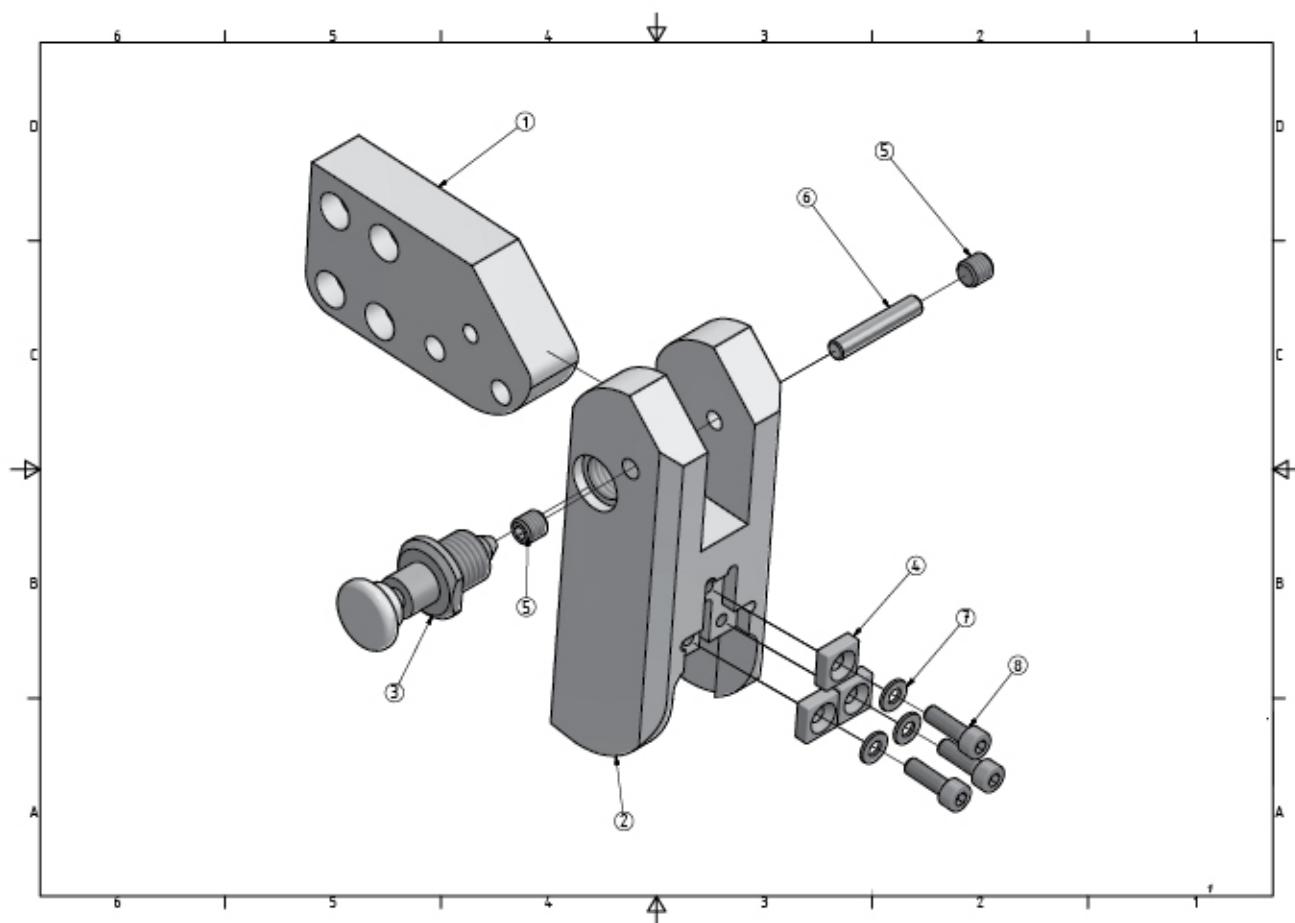

PART LIST

PART	PCS	PART NO
1	1	530.102.1201
2	1	530.102.1202
3	1	530.102.1130
4	3	530.102.1108
5	2	Bolt
6	1	530.102.1203
7	3	Shim
8	3	Bolt

SPARE PART LIST

Saw Handle - Handle Diagram

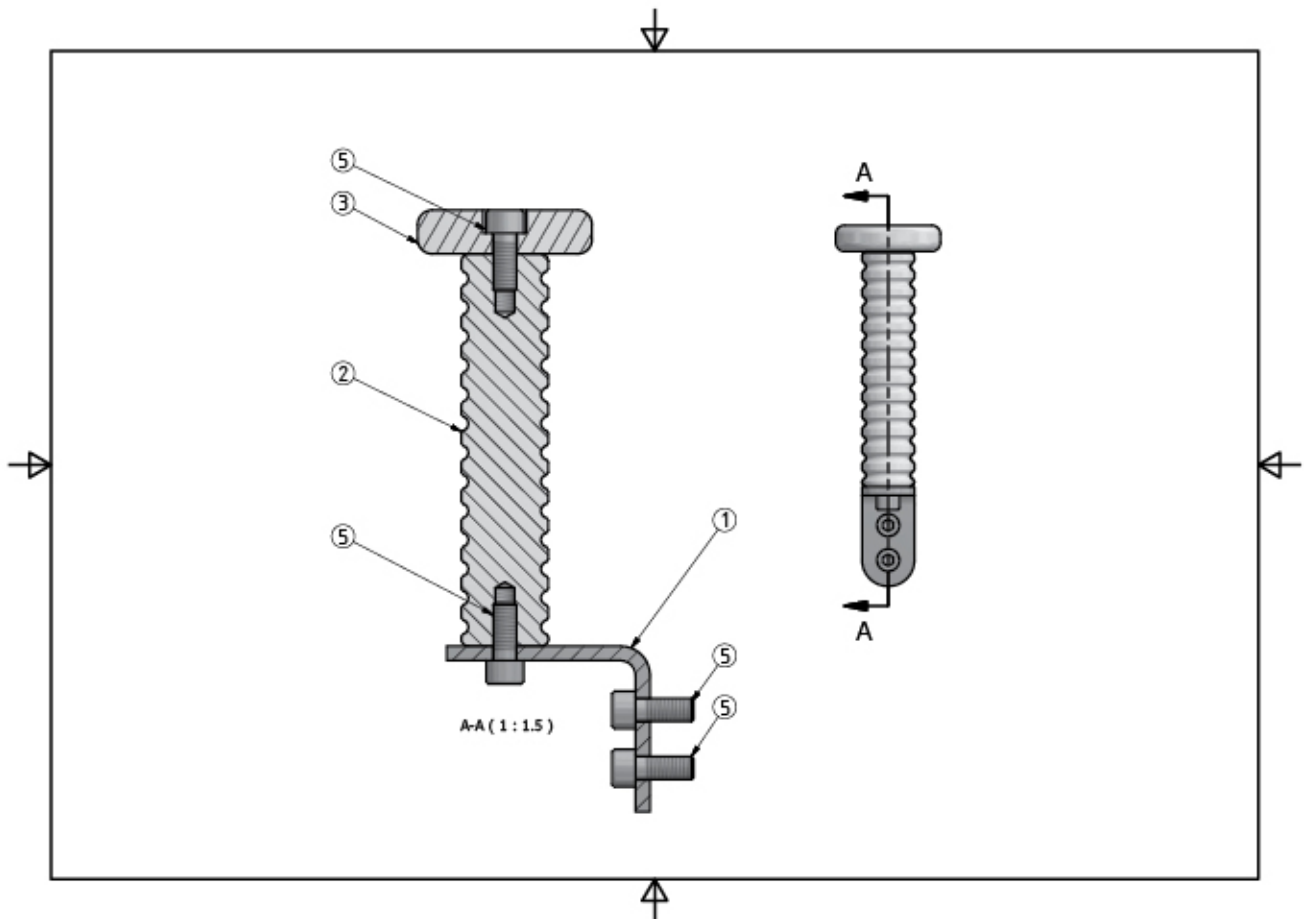

PART LIST

PART	PCS	PART NO
1	1	530.102.1302
2	1	530.102.1301
3	1	530.102.1303
5	4	Bolt

SPARE PART LIST

Trigger Pulley Diagram

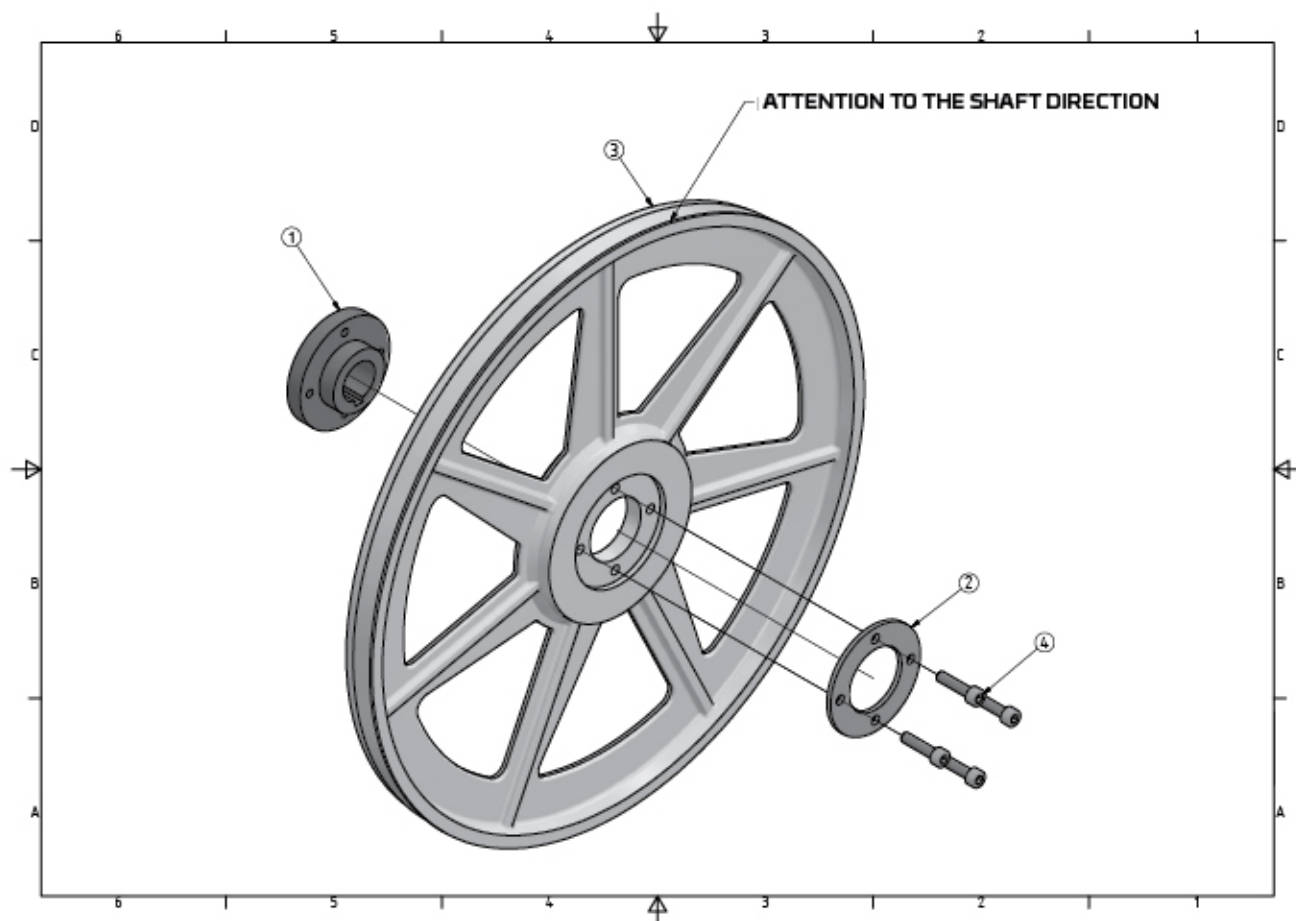

PART LIST		
PART	PCS	PART NO
1	1	530.102.2002
2	1	530.102.2003
3	1	530.102.2001
4	3	Bolt

SPARE PART LIST

Trigger Engine and Gear Overview Diagram

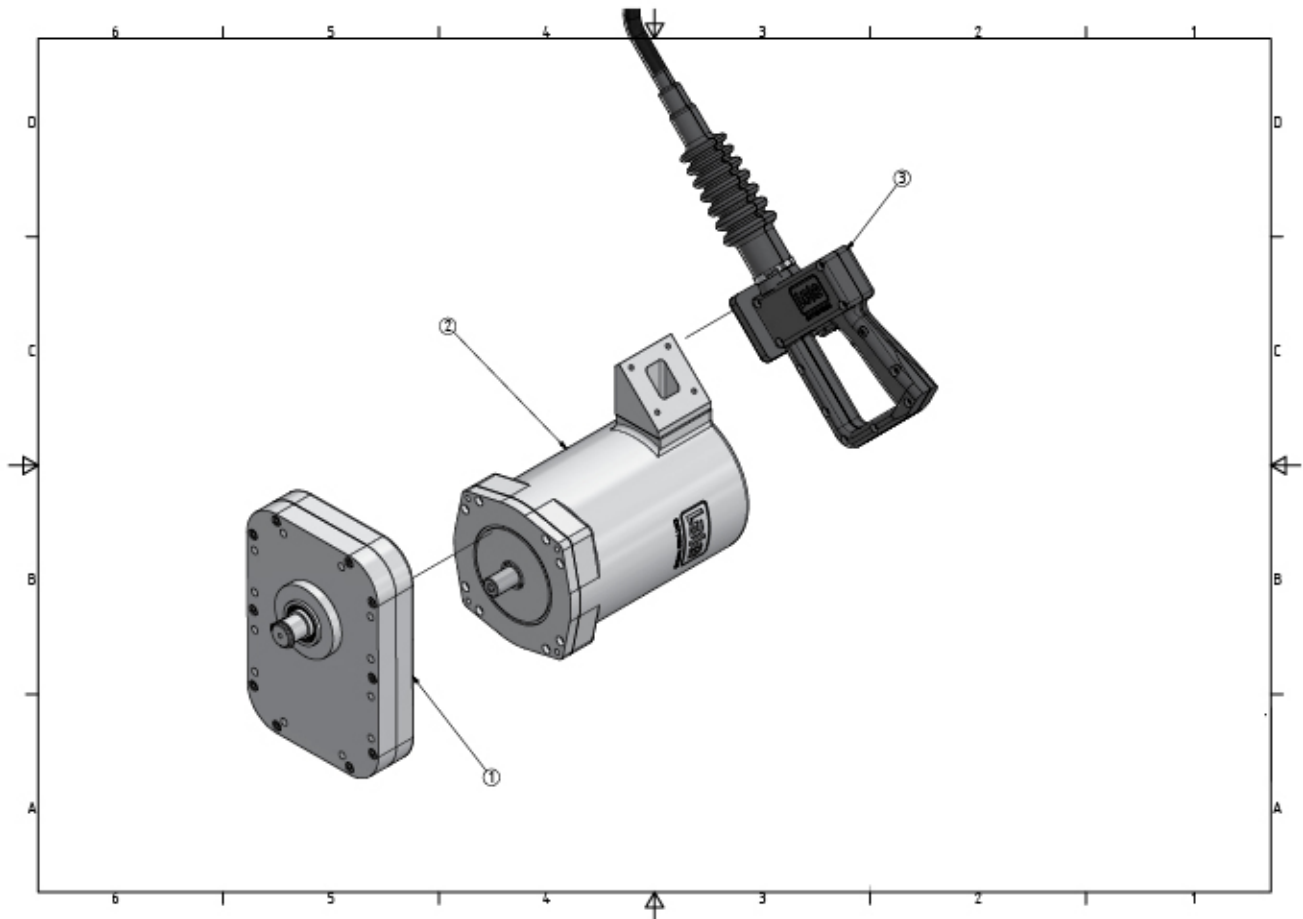

PART LIST

PART	PCS	PART NO
1	1	530.102.3200
2	1	530.102.3300
3	1	530.102.3400

SPARE PART LIST

Trigger Connection Diagram

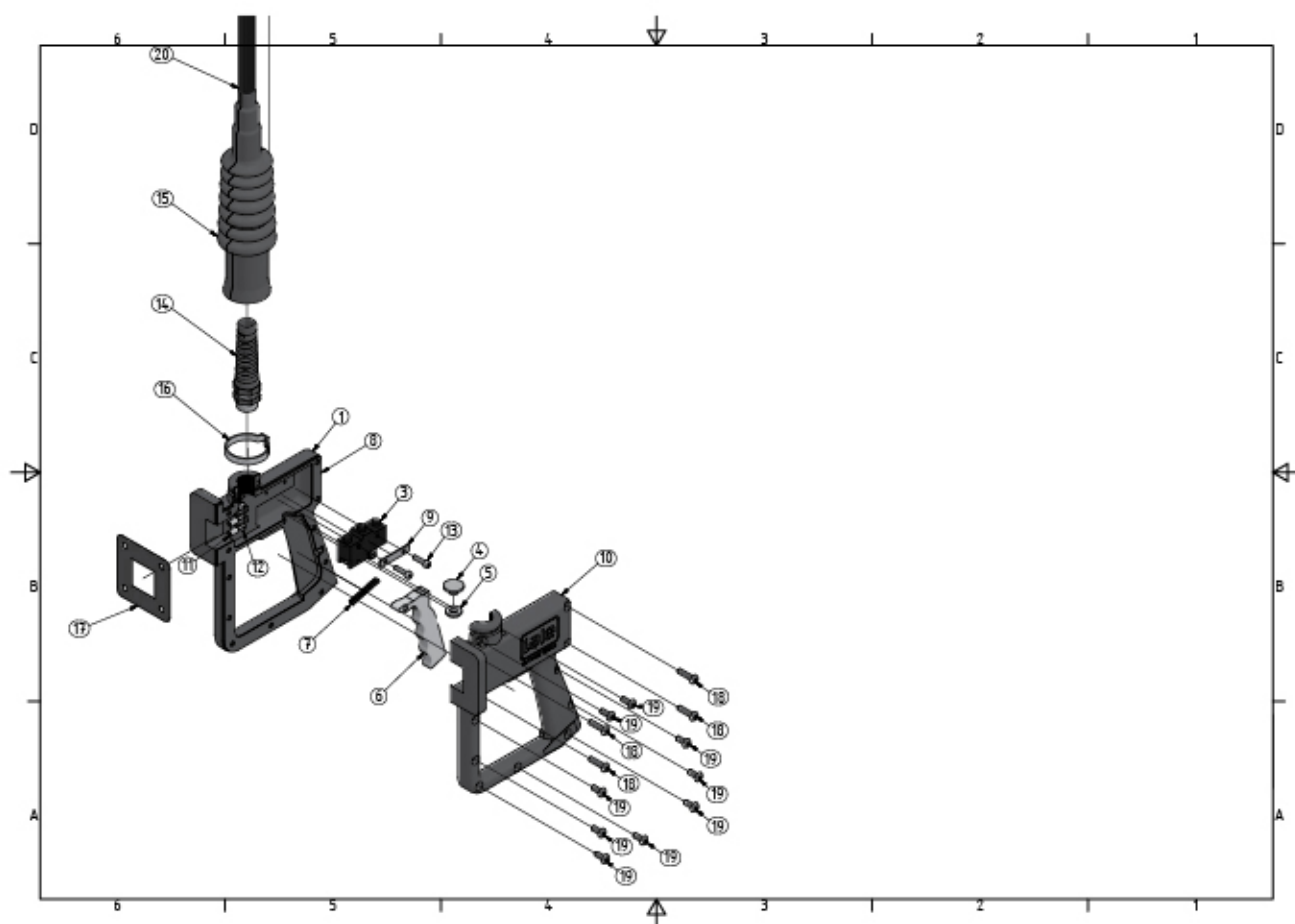

PART LIST

PART	PCS	PART NO
1	1	530.102.3411
3	1	Switch
4	1	530.102.3416
5	1	530.102.3417
6	1	530.102.3413
7	1	Arc
8	1	530.102.3414
9	1	530.101.3412
10	1	530.102.3412
11	3	Cable Connection Point
12	3	Bolt
13	2	Bolt
14	1	530.101.3404
15	1	530.101.3405
16	1	530.102.3403
17	1	530.102.3404
18	4	Bolt
19	9	Bolt
20	1	Cable

SPARE PART LIST

Front Stay Connection Diagram

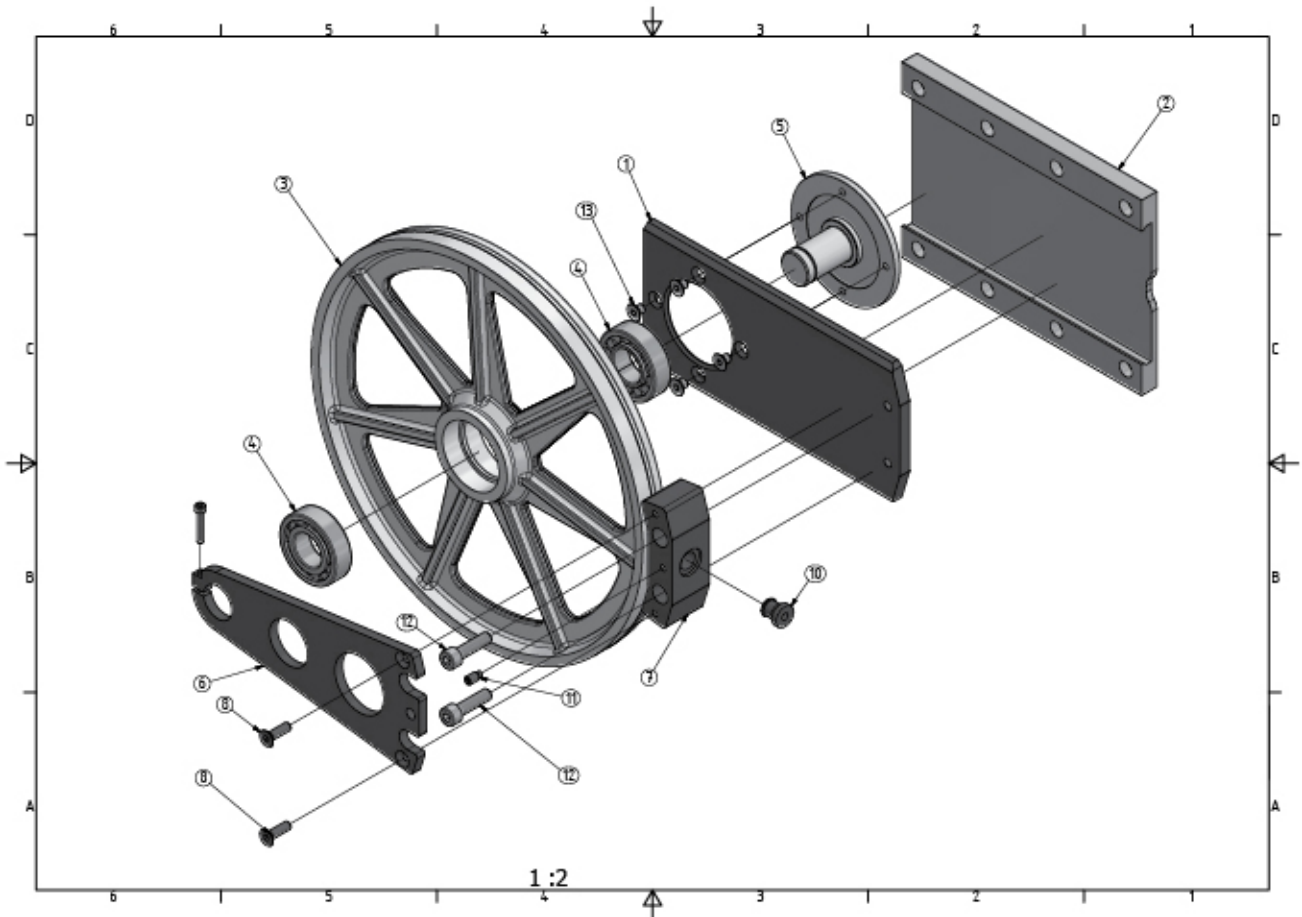

PART LIST

PART	PCS	PART NO
1	1	530.102.4002
2	1	530.102.4005
3	1	530.102.4201
4	2	Bearing
5	1	530.102.4007
6	1	530.102.4009
7	1	530.102.4008
8	2	Bolt
9	1	Bolt
10	1	530.102.4006
11	1	Bolt
12	2	Bolt
13	4	Bolt

SPARE PART LIST

Irrigation System Connection Diagram

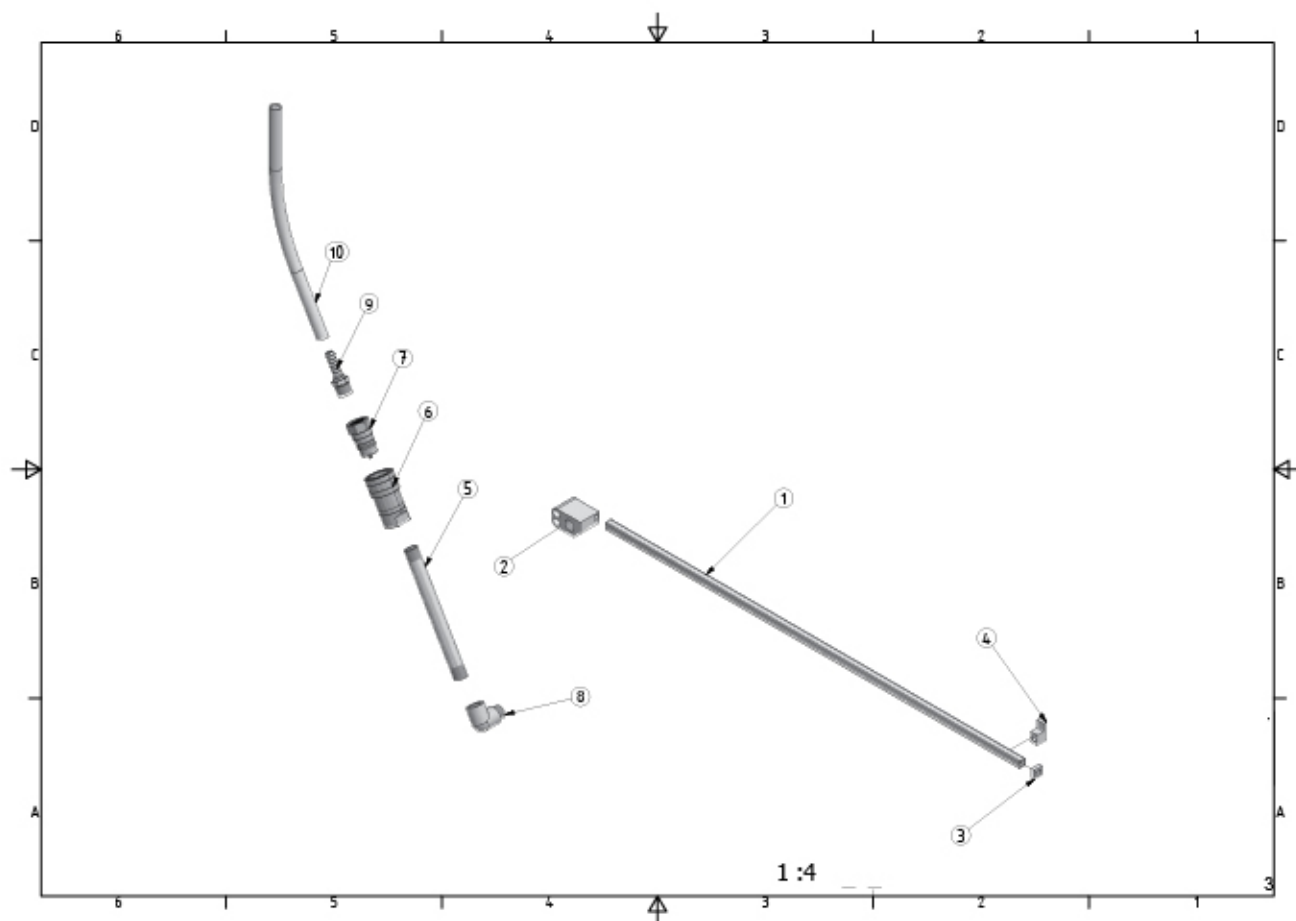

PART LIST		
PART	PCS	PART NO
1	1	530.102.5001
2	1	530.102.5002
3	1	530.102.5004
4	1	530.102.5005
5	1	530.102.5006
6	1	530.102.5007
7	1	530.102.5008
8	1	Stainless Bend
9	1	530.102.5009
10	1	Water Hose

SPARE PART LIST

Cover Assembly Diagram

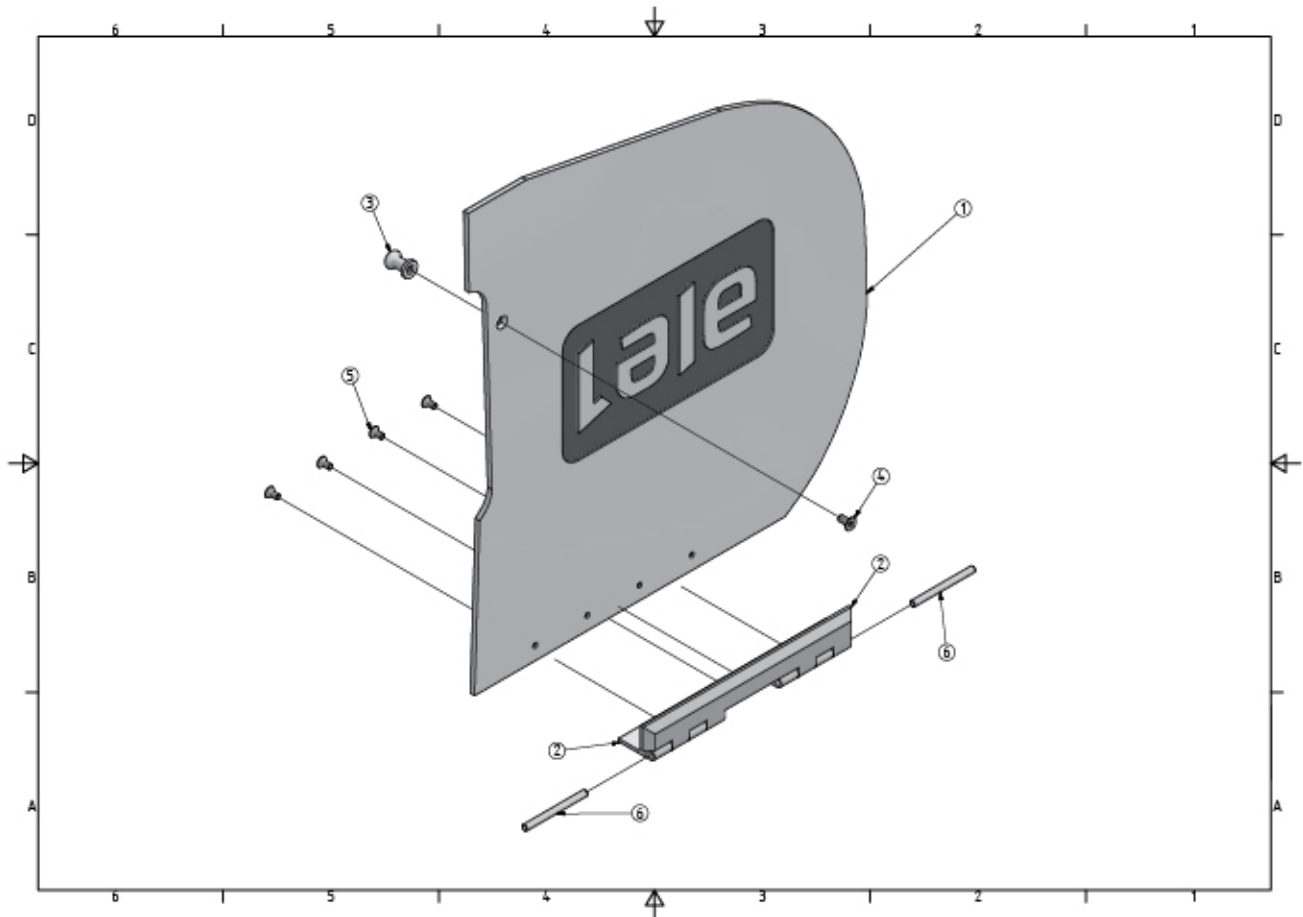

PART LIST

PART	PCS	PART NO
1	1	530.102.6101
2	2	530.102.6001
3	1	530.102.6002
4	1	Bolt
5	4	Bolt
6	2	530.102.6004

SPARE PART LIST

Hanger System Connection Diagram

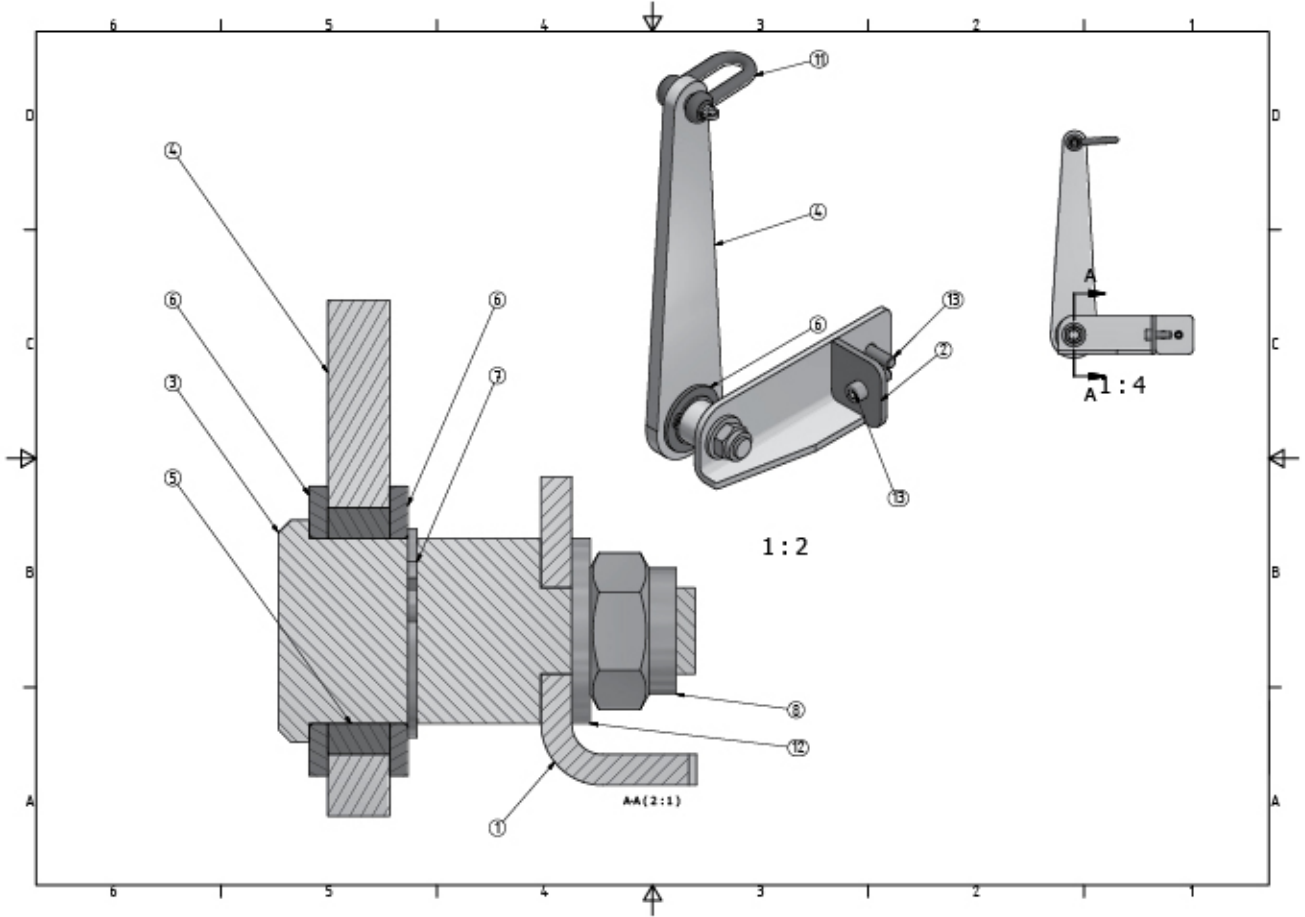

PARÇA LİSTESİ

PARÇA	ADET	PARÇA NUMARASI
1	1	530.102.6501
2	1	530.102.6502
3	1	530.102.6504
4	1	530.102.6503
5	1	530.102.6505
6	2	Stainless Shim
7	1	Ring
8	1	Nut
11	1	Eyebolt
12	1	Pul
13	3	Bolt

KBT-650 ENGINE LABEL

CEMSAN MEZBAHANE SİSTEMLERİ A.Ş
Saray Mah. 4.Cad. No:51 K.Kazan-Ankara- TURKEY
+90 312 801 0 222 info@lalesaws.com

PRODUCT NAME / ÜRÜN ADI : CARCASS SPLITTING SAW
KARKAS BÖLME TESTERESİ

MODEL: KBT-650

POWER/GÜÇ: 3 Kw 3.1 Hp

VOLTAGE/VOLTAJ: 380V/50 Hz

PRODUCT YEAR/ÜRETİM YILI:

SERIAL NO/SERİ NO: On the package



MADE IN TURKEY

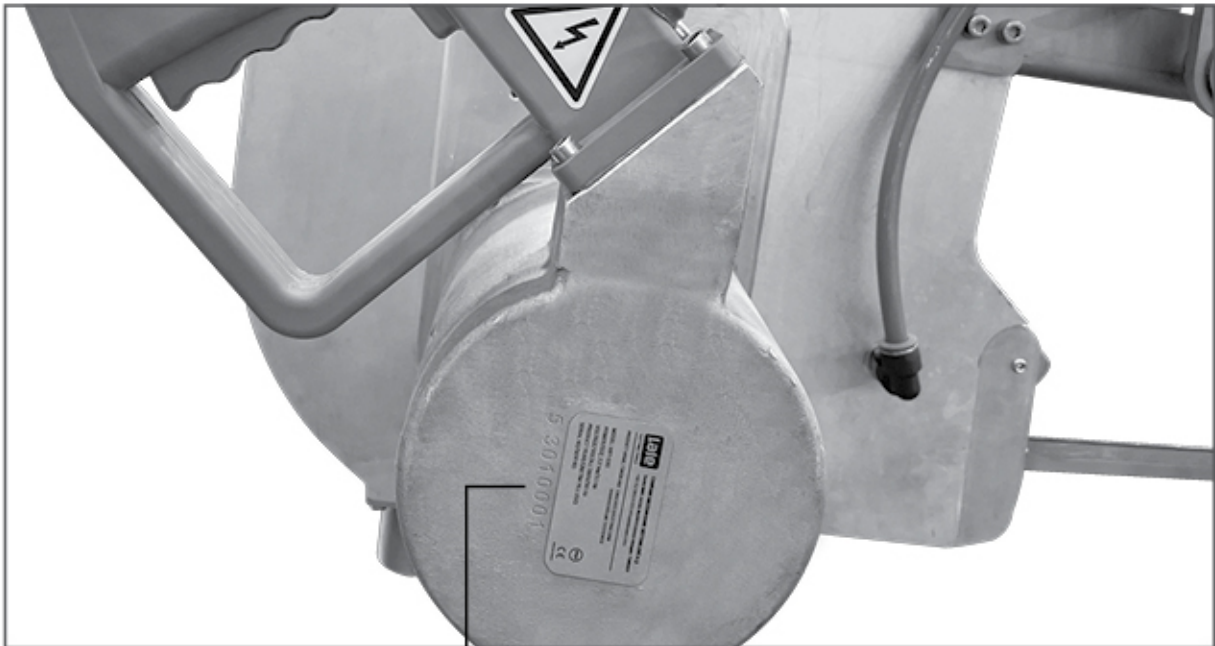

→ Product Serial No

ELECTRICAL PANEL

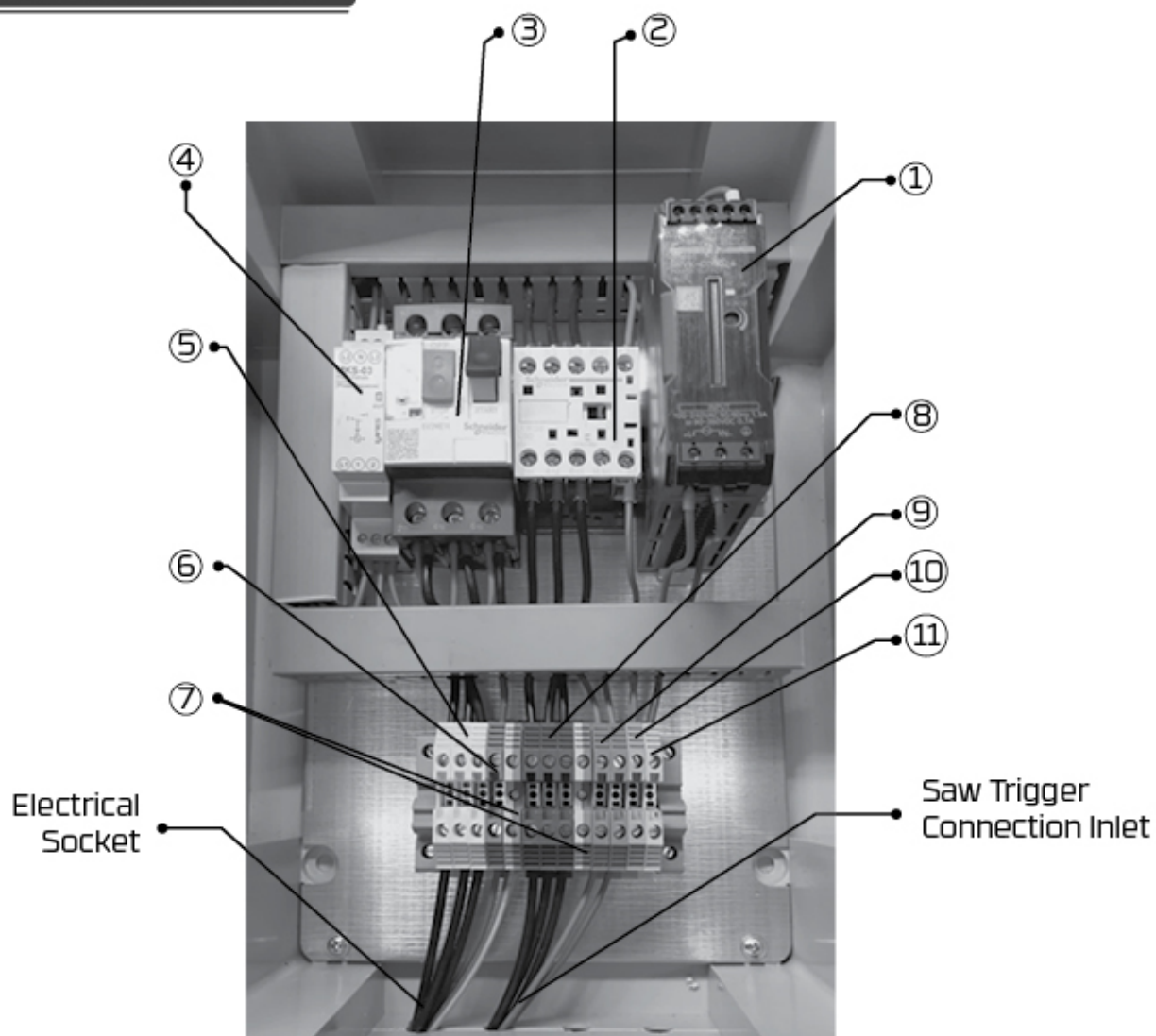





PART LIST

PART	PCS	PART NO	DEFINITION
1	1	530.102.8001	
2	1	530.102.8002	
3	1	530.102.8003	
4	1	530.102.8004	
5	3	530.102.8005	White
6	1	530.102.8006	Blue
7	2	530.102.8007	Green-Yellow
8	3	530.102.8008	Brown
9	2	530.102.8009	Red
10	1	530.102.8010	Orange
11	1	530.102.8011	Yellow

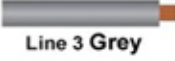

ELECTRICAL SOCKET

	Single Phase	Three Phase
Phase Conductor (Line)	 Brown	 Line 1 Brown  Line 2 Black  Line 3 Grey
Neutral Conductor	 Blue	
Protective Conductor (Earth)	 Green-and-Yellow	

Three-Phase Socket Connection

There is not any difference between installation of three-phase socket and one-phase socket installation logically. Three-phase socket compose of 3 live point + 1 ground + 1 neutral wire, while one-phase socket composes of 1 live point + 1 ground + 1 neutral wire. If you see four wires, there is no need for pulling ground wire. The ground wire is required usually for engines. The three-phase socket's cable section you will use should be choosen according to maximum flow carried in the machine in the result of the calculations made.

You can see the colors of one-phase and three-phase wires determined according to BS 7671 and IEC 60446 standards in image 1. In three-phase wires, R phase is grey, S phase is black, and T phase is Brown, neutral blue, and ground is yellow or green. In one-phase wires, the colors are brown (phase), blue (neutral), and yellow-green (ground).

Three-Phase Socket Connection

There is not any difference between installation of three-phase socket and one-phase socket installation logically. Three-phase socket compose of 3 live point + 1 ground + 1 neutral wire, while one-phase socket composes of 1 live point + 1 ground + 1 neutral wire. If you see four wires, there is no need for pulling ground wire. The ground wire is required usually for engines. The three-phase socket's cable section you will use should be choosen according to maximum flow carried in the machine in the result of the calculations made.

First, the wire points which will be connected should be prepared. After cleaning of the wire points, they should be bent in the shape of semicircle for an easy connection process. You can use pliers for this procedure. You can see outputs of three-phase + 1 ground wire or three-phase + 1 ground + 1 neutral wire for the working princible of the device which the socket will supply.

Image 2: 3P+N+T scheme of socket's connection

The socket connection of three-phase socket of the wires shaped as 3P + N + T must be done as in image 2.

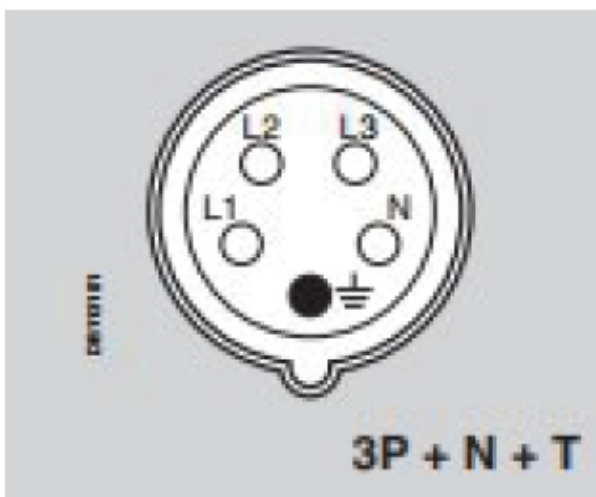

IMPORTANT NOTE: Electricity has a fatal impact and carries high risk of danger. Before starting to working, The power supply must certainly be turned off and necessary checks need to be done. It is also suggested for you to put warning sign on breaker box or on panel. Ensure that all the processes are done by certified and authorised personnel!

SAW MAINTANENCE INSTRUCTIONS

A - DAILY SAFETY CONTROLS

- Examine whether all the parts are proper by visual test.
- Check the electricity connection.
- Check whether all the movable parts are in their right place.
- Check whether the blade's saw is in its right place.
- Check balancer connection and attraction force by testing.

B - DAILY CLEANING OF THE SAW

- The saw requires to be cleaned every day.

C - MAINTANENCE AND TROUBLE SHOOTING

- The saw's general inspection, cleaning and periodical maintenance needs to be done so that it can be durable.

D - MAINTANENCE PERIODS

- Daily, weekly, monthly, and six-month inspections are suggested to be made.
- There will be grease oil which needs to be changed in every six-months in gear case. The grease oil to be used must be semi-fluid grease Epro O.

E - REASONS FOR FAULTS AND REQUIREMENTS

- In case of any sound, noise, vibration, or any abnormality which foreshadows possible malfunction during the cutting process, examine the attached table.

SAW TROUBLE SHOOTING

MALFUNCTION	POSSIBLE REASON	SUGGESTION
Not running or stopping of the electric motor	Non availability of electricity	Check whether the electric cable is plugged in the socket, there is not any damage on it, and electrical fuse.
Running loudly	Blade connection's loosening.	Check the connections of the saw's connection bolts.
Cutting power is not enough.	The saw may blind, or attraction force setting of the balancer may collapse	Switch the saw's blade with the new one, reset the attraction force of the balancer.
Anormal noise of drive systems	Grase of gear box may become spoiled. Phase of electric connection may be disconnected.	Check the bearings and gears in gear box. Check the phases in electric connection.
Heating of electric engine	The electric cables may not have been selected accurately, or cable connection may loosen, or electric phases may be broken off	Use the suggested electric cable, make measurement mid phase. Check the cable connection.
The saw does not cut at all.	The direction of saw's cutting may be opposite, get blinded. Brown out!	Check the direction of saw's cutting. Check the depth of cut. Check the voltage mid phase.
Cutting blade sticks to the meat.	Shearing blade may be incorrect, get blinded or deformed.	Check the blade and switch it with the new one.
The engine is running, but the blade does not rotate.	Fault in gear box, connection wedge fault.	Check the gear box.

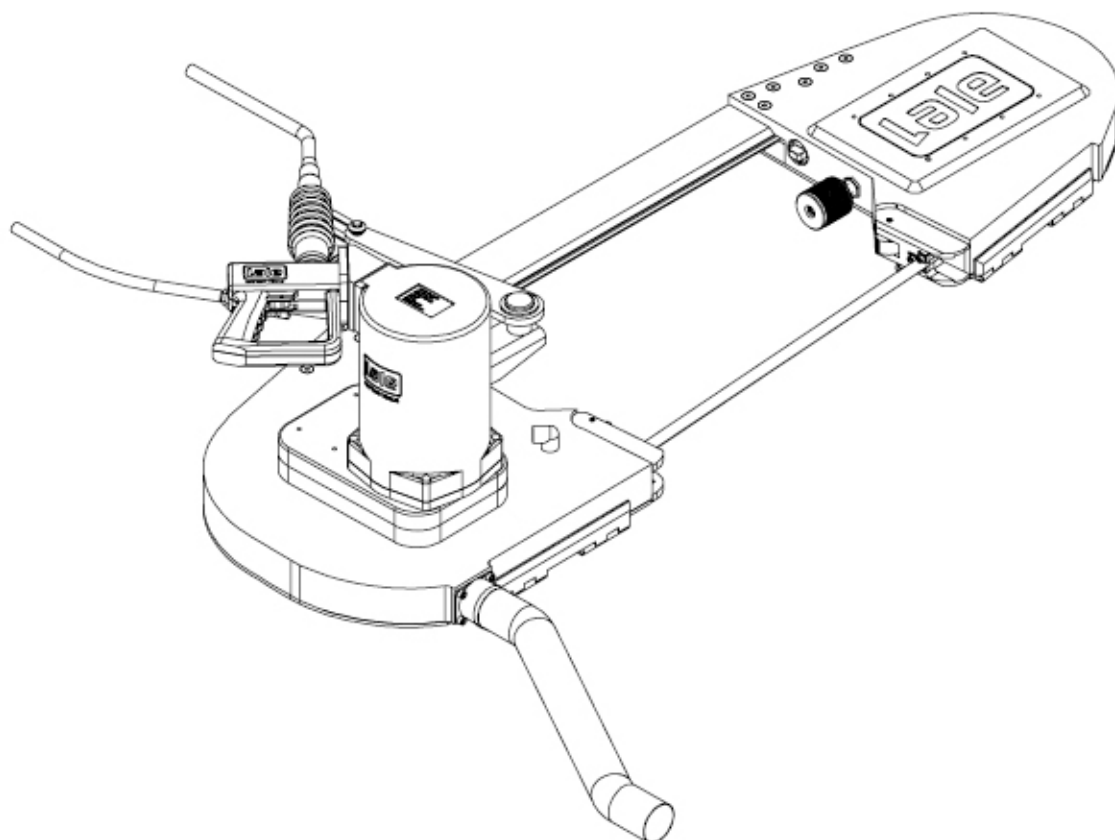
SAFETY MEASURES

- It is necessary to consider the following safety when operating the band saw.
- Untrained and inexperienced personnel should not use the machine.
- Check the machine for any damage.
- Carefully maintain the machine.
- Keep the work area safe and clean.
- Wear suitable work clothes.
- Be sure that you are standing in a safe position.
- Install the machine in accordance with the rules.
- Turn off the switch or disconnect the power supply.



APPLICATION/DESCRIPTION

The correct use of the carcass splitting saw is as follows:

It should be positioned so that the starting angle is 45°. When the cutting begins, descend with the carcass division platform and continue with 25° and the cut angle should be decreased as you descend.

CORRECT USAGE

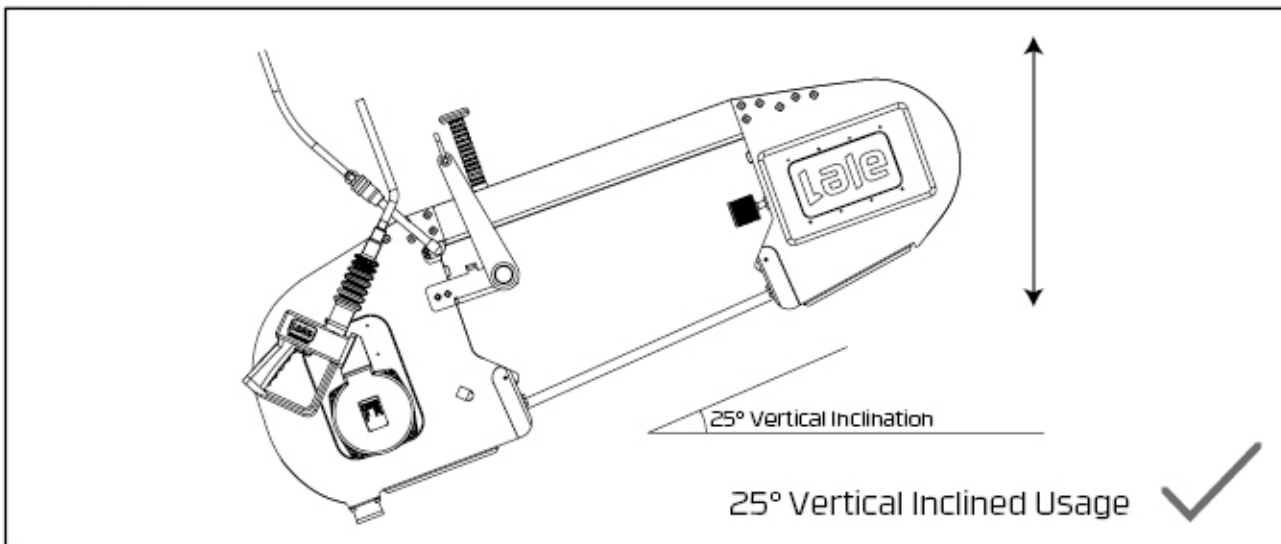

FALSE USAGE

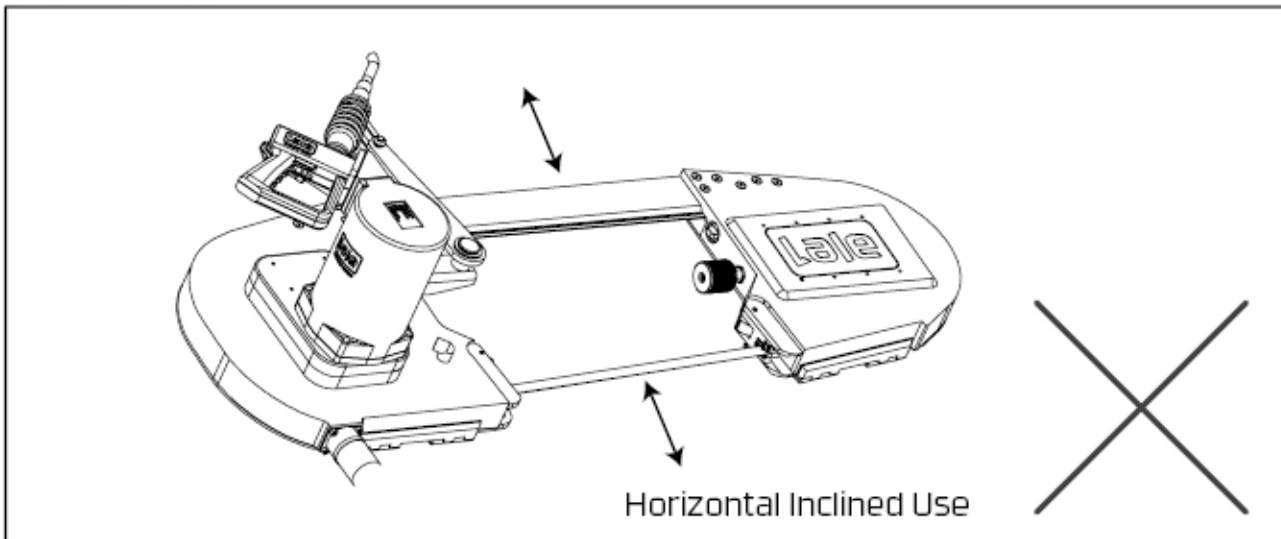

APPLICATION/DESCRIPTION



PRODUCT USAGE TYPES:

- ! Cattle Carcass
- ! Pig Carcass

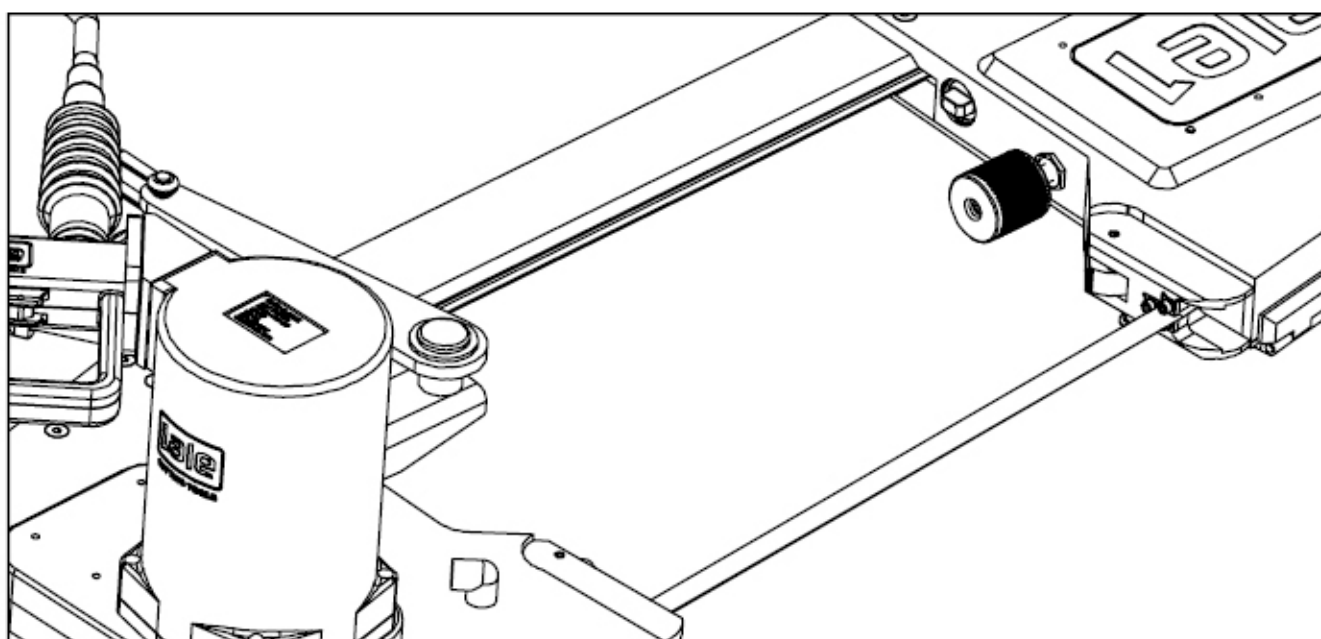

**APPLICATION/DESCRIPTION**

Newly developed electric carcass splitting saw

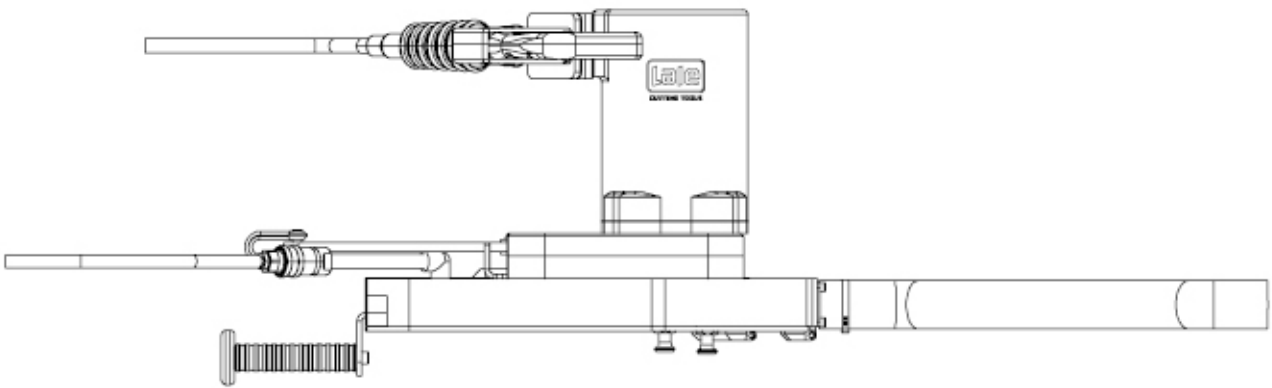

500mm width blade opening

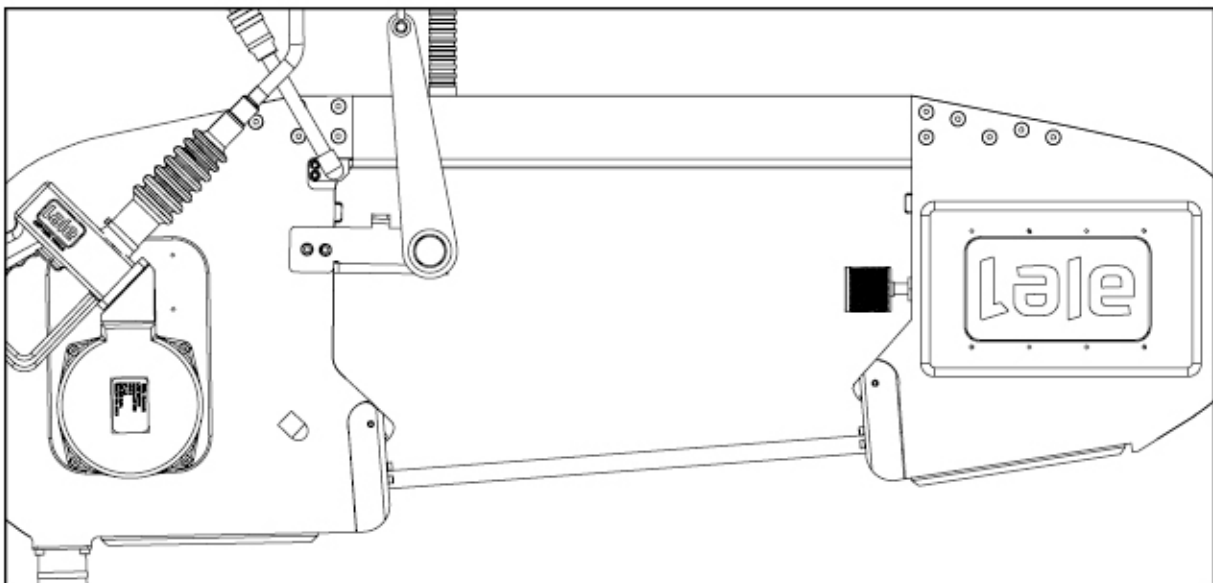

APPLICATION/DESCRIPTION



Long life blades

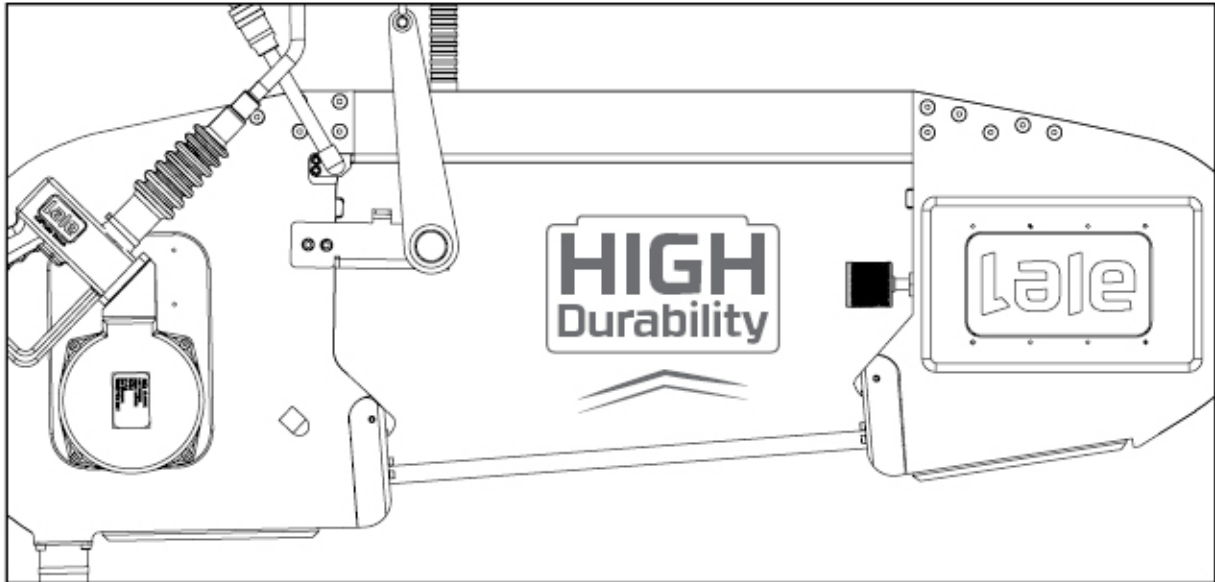

Fast and easy cleaning and sterilization thanks to its perfect design

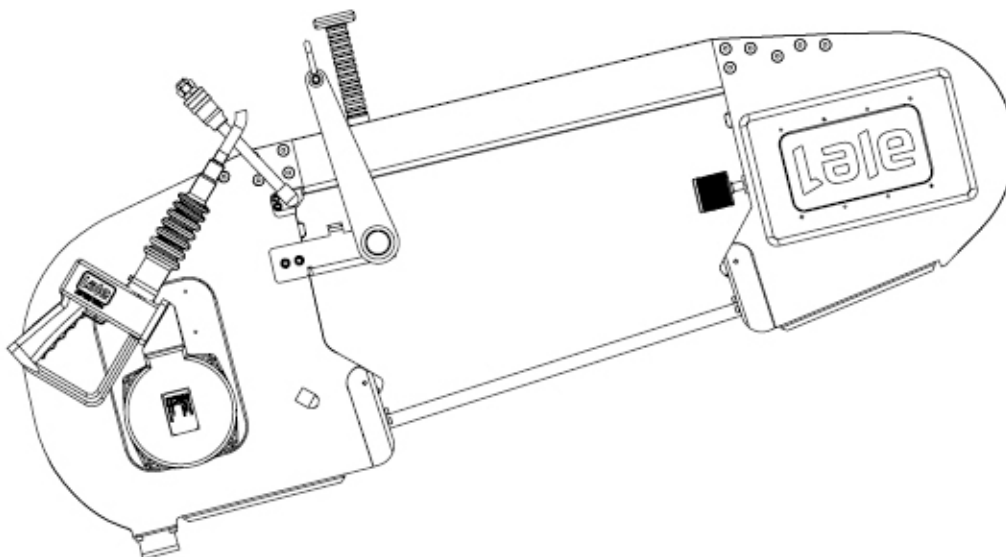

**APPLICATION/DESCRIPTION**

Safe working thanks to dual safety control
(Anti-tie-down)

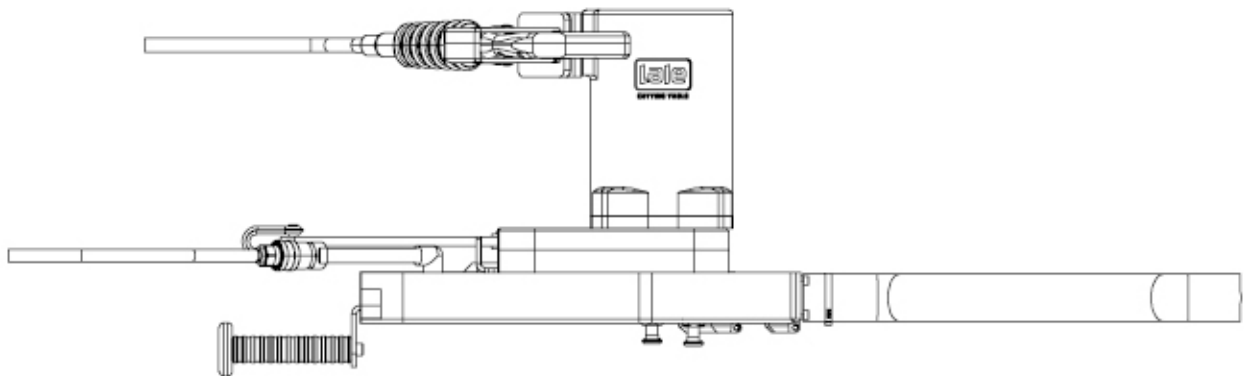

Waterproof
Ergonomic

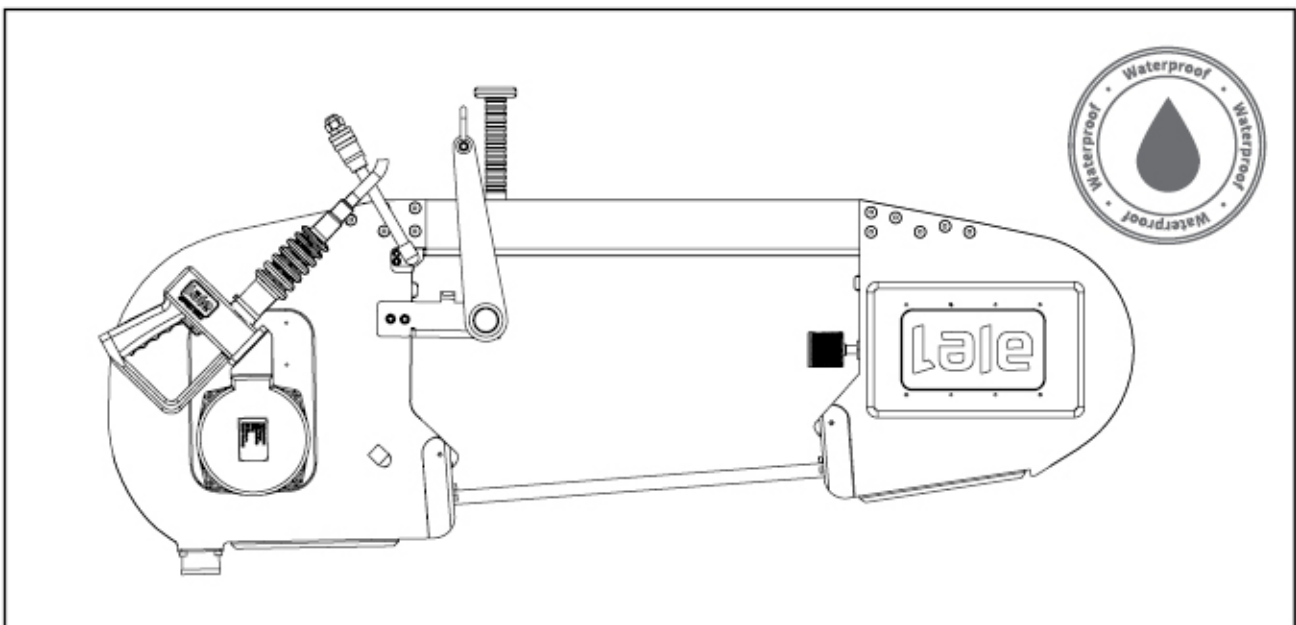

TECHNICAL SPECIFICATIONS

Physical Properties

Weight	Blade Opening	Cutting Height
68 kg	500 mm	330 mm

Water Inlet

Water Connection
3/8 inch

Usage of Electric

Phase	Voltage/Frequency/Power	Trigger	Protection Class
3	380 V / 50Hz / 3 Kw (3.1hp)	24 Volt Start Switch	IP67

Type: KBT 650

The blade opens from the middle

Operation: Electric

Control: Electric double trigger anti-tie-down

Cutting speed under load .15 seconds

Recommended balancer capacity: 60-70kg

Manufacturer **Lale Cutting Tools** Ankara/Türkiye

INSTALLATION / OPERATING PRINCIPLE**Installation ■**

After lifting the balancer high enough, tie it with the safety chain ■
and connect the saw ■

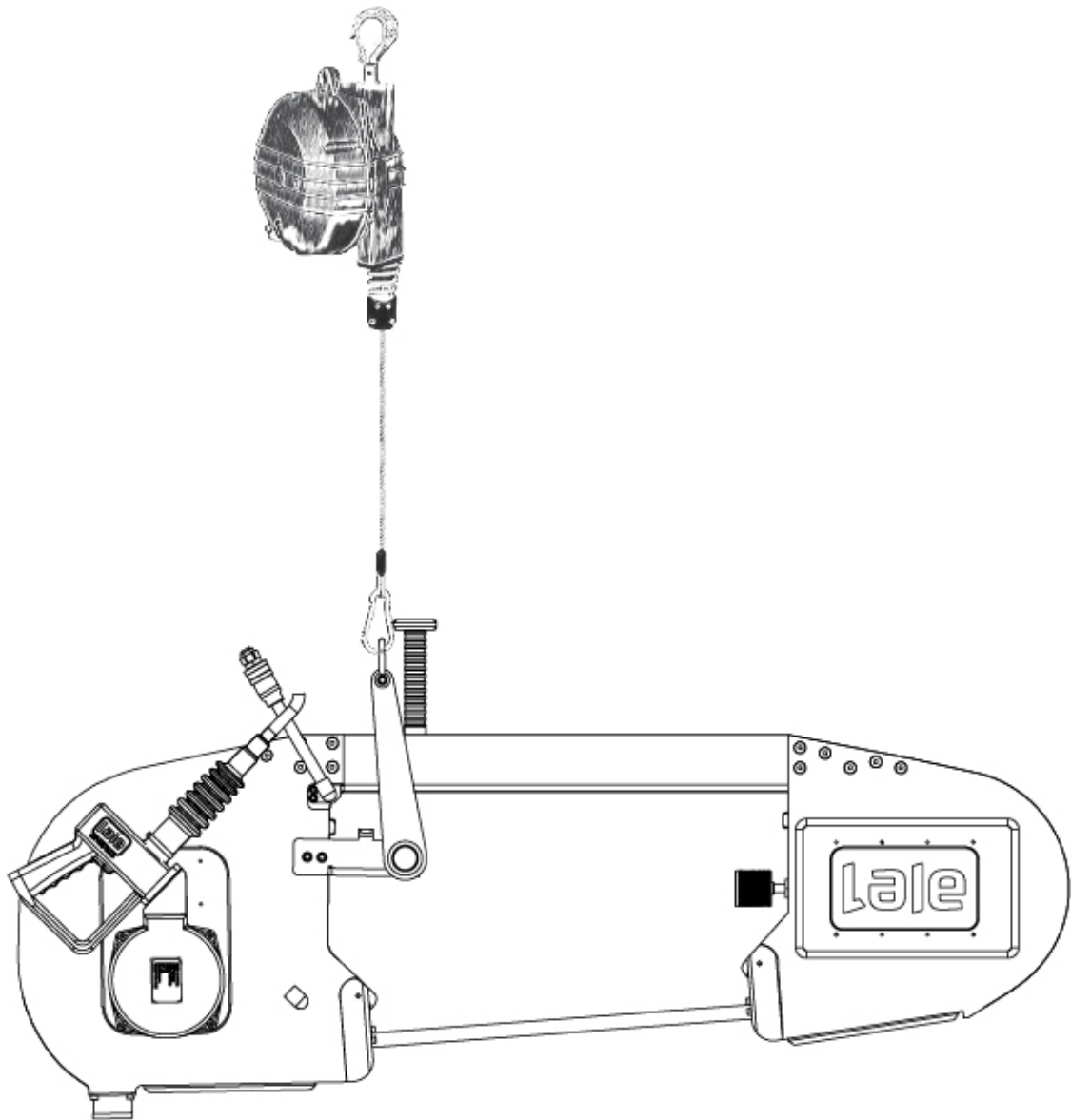

Turn on the power unit from the main switch. ■
Connect the water line. The pressure must be at least 2 bar. ■

INSTALLATION / OPERATING PRINCIPLE

■ Working Principle

- Lift open blade to body
- To run it, press and hold the triggers of both levers at the same time - do not use excessive force.
- After the splitting process is complete, release the triggers pressed. Thus, the device stops automatically.

■ Maintenance

- The effort of the cut depends on the sharpness of the blade.
- The blade should always be sharp.
- After you're done, clean the shears, lubricate the pivot bolts, and lubricate the blades with food oil.

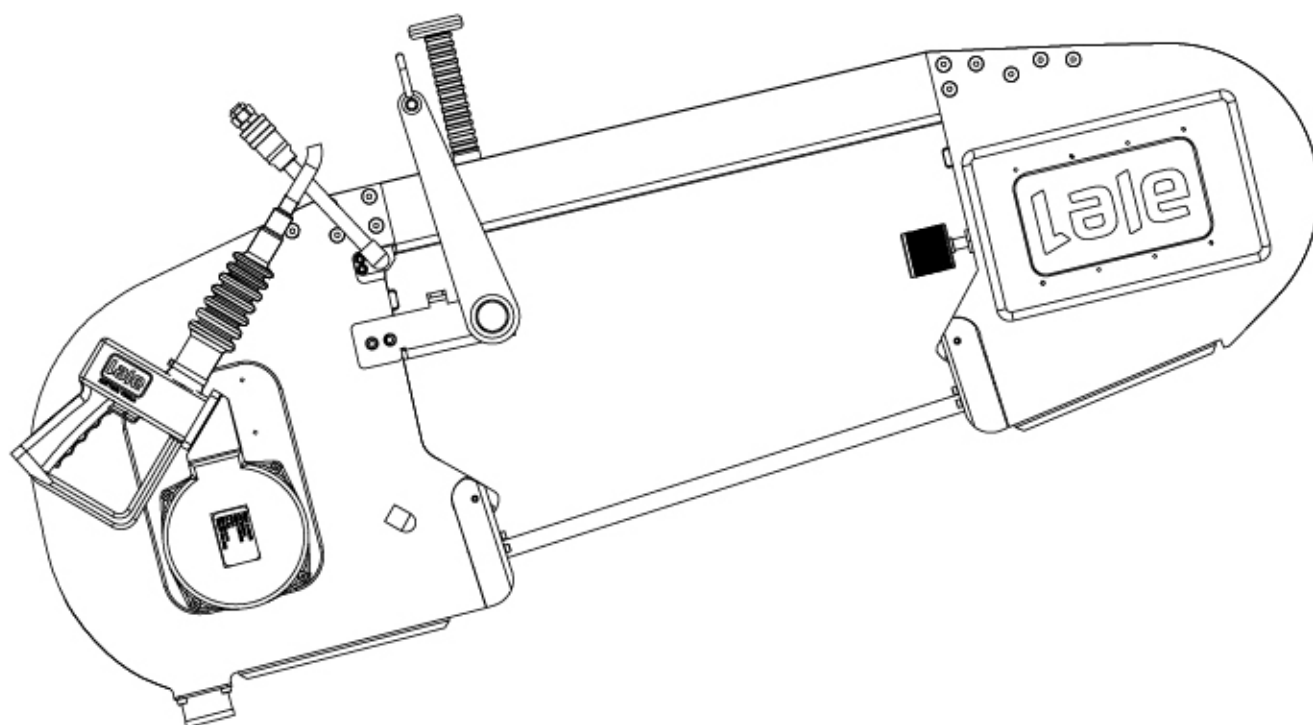

COMPATIBLE "PREMIUM" BAND SAW BLADE

Model No *

33-D3	3248mm x 19.6mm x 0.56mm 3TPI
32-D3	3225mm x 19.6mm x 0.56mm 3TPI
28-D3	2864mm x 19.6mm x 0.56mm 3TPI

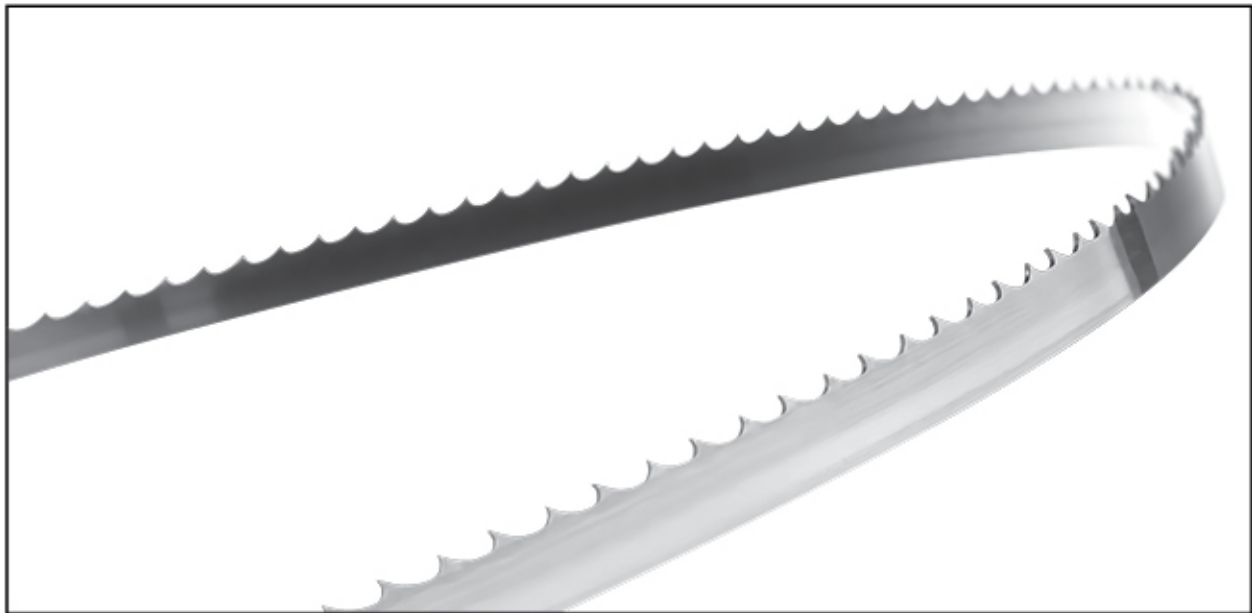

- Long shelf life thanks to high quality stainless material.
- Satinet surface; Thanks to the satinated smooth surface, it does not cause damage to the interior parts and does not wear out the machine.
- Long operating time thanks to angled teeth and back hardened by induction heat treatment.
- Strong and sharp teeth, completely sanded and specially processed.
- Fast and easy cutting with little effort.
- Fast and easy cutting with little effort.

** Not supplied with the product. Call to buy.*

BALANCER

Compatible balancer model no: YDP-70*



Balancer Technical Specifications

Model No	YDP-70
Capacity	60-70 kg
Cable Length	3 mt
Weight	25.5 kg

- Corrosion resistant aluminum alloyed leakproof monoblock body.
- Stainless steel rope.
- Adjustable weight with worm screw.
- Safety device against load drop.
- Top rotary suspension with safety hook.
- Locking key.
- Adjustable tapered shaft.
- Bearing tapered shaft.
- Friction reducing cable guide.
- 360° rotating upper hook with bearing.

* Not supplied with the product. Call to buy.

COMPATIBLE DISINFECTION CABINET

It is the cabin on the Carcass Splitting Platform that allows the saw to be disinfected immediately after the slaughtered animal. The cabin works connected to the Carcass Splitting Platform with a chassis connection. It is designed to disinfect the saw in a healthy and homogeneous way. The saw cabinet is detected by a sensor when the saw is placed inside the cabinet, and the washing process is started automatically with the solenoid valve. When the saw is removed, the washing is terminated and the cutting process continues.

The disinfection cabinet must be purchased separately from the product.

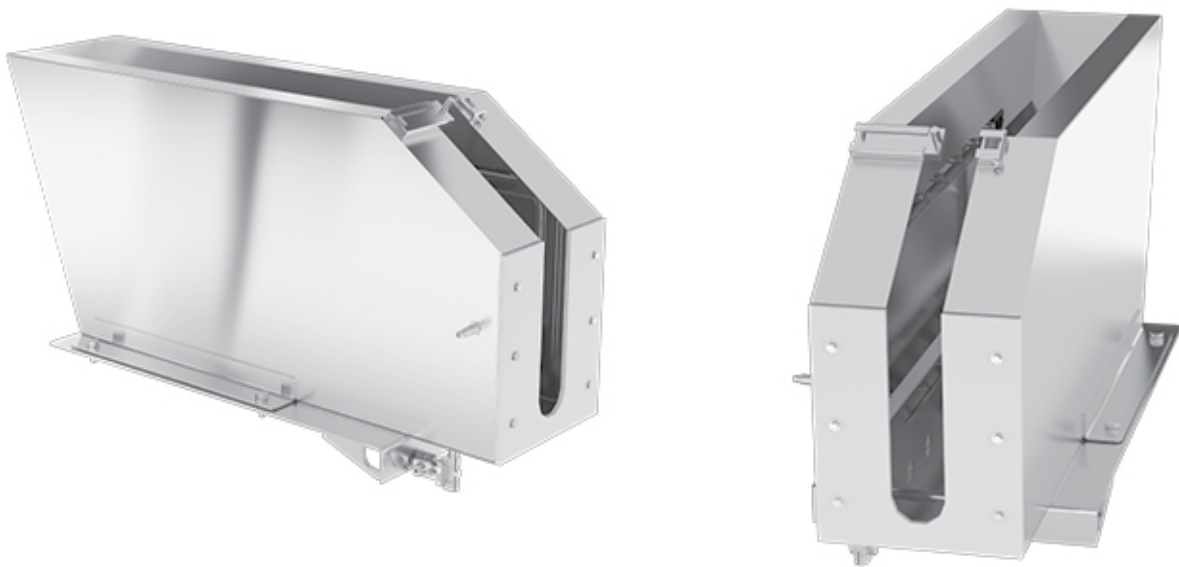

External Dimensions	1350 x 340 x 617mm (L x W x H)
Chassis Material	AISI 304
Chassis	40 x 40 Box Profile and 2mm Sheet
Saw Slot	Polietilen
Voltage	24 Volt
Frequency	50 Hz
Nozzle Quantity	30 pcs
Water Treatment	Ø21,3 x 2 mm AISI 304 Quality

** Not supplied with the product. Call to buy.*

KBT-650

CARCASS SPLITTING SAW



CUTTING TOOLS



Saray Mahallesi, 4. Cadde No: 49
Kahramankazan / Ankara / TÜRKİYE
+90 801 02 22 • info@lalesaws.com

